

PRECISION RING DRIVE SYSTEMS

Based on Nexen's innovative Roller Pinion technology, Nexen Ring Drive Systems come complete with a precision grade, high capacity bearing and drive mechanism in a rigid housing. With options for high speed, high torque and zero backlash, Nexen Ring Drives can be optimized for every application. With accelerations up to twice as high as other indexing technologies, Nexen Ring Drive systems provide more productivity while boasting low maintenance, high efficiency and long life.



PATENTED

The most advanced technology in rotary motion control.

The Nexen Ring Drive Advantage

Based on Nexen's innovative Roller Pinion technology, Nexen Ring Drive (CRD & PRD) systems come complete with a precision grade bearing and drive mechanism in a rigid housing to simplify the selection process. With all the great features of our other advanced RPS technology, the Ring Drives open up new design possibilities to next generation machines.

- **High Indexing Precision**

With an indexing precision up to ± 11 ArcSec and repeatability up to ± 1.2 ArcSec, Nexen's Ring Drives offer unmatched mechanical system capabilities.

- **Zero Backlash**

Unlike other mechanical drive systems, the CRD offers zero backlash options from the motor through the driven load.

- **High Load Capacity**

With the precision grade, high load capacity cross-roller bearing, Nexen Ring Drives can handle loads up to 1575 kN.

- **High Speed**

Nexen Ring Drives can handle speeds up to 304 RPM. Unlike traditional cam driven systems, Nexen Ring Drives can handle peak torque inputs at any time. This allows for indexing times up to 2x faster than the competition.

- **Smooth in Motion**

Combining Nexen's RPS technology with a preloaded cross-roller bearing and an integrated motor/precision gearhead gives a rigid, smooth system.

- **High Torque Holding**

With the optional zero backlash holding brake, the CRD can hold loads up to 800 Nm (available on CRD250, other sizes pending) while still maintaining an open center.

DEPENDABLE. VERSATILE.
OPTIONS THAT DELIVER.

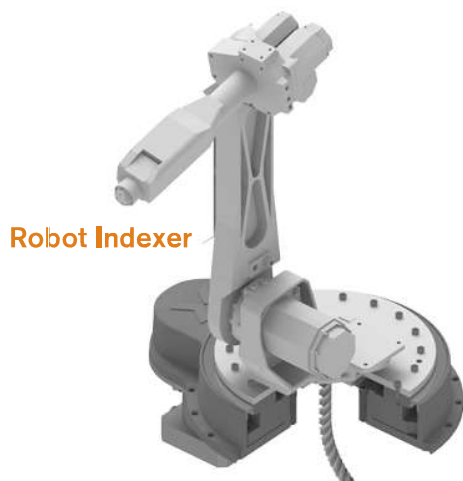

Robot Indexer

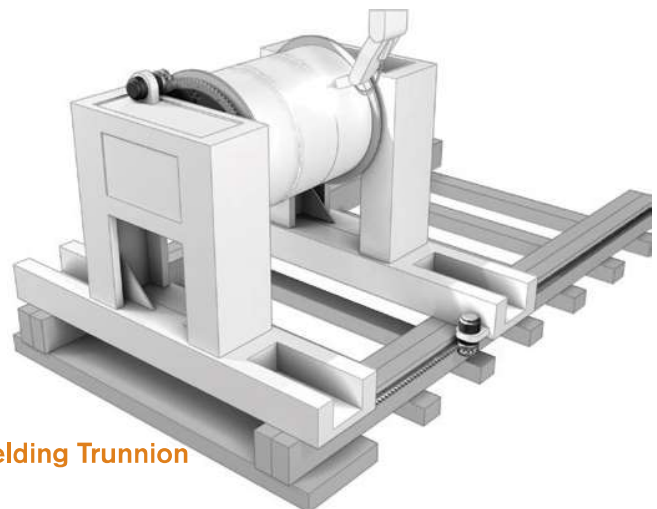

Welding Trunnion

CRD: A DRIVE STATION FOR EVERY APPLICATION



High Precision Planetary (PL)
FLEXIBLE GEARHEAD RATIO

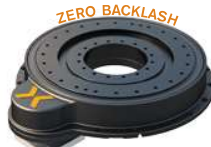

Motor Ready Sealed (MRS)
READY TO ACCEPT MOTOR/GEARHEAD



Harmonic Gearhead (HG)
HIGH RATIO GEARHEAD

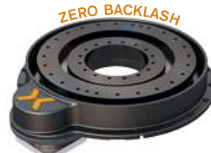

Motor Ready Guarded (MRG)
READY TO ACCEPT MOTOR/GEARHEAD

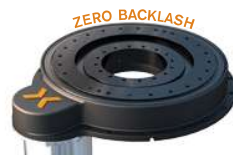

Direct Drive Pinion (DD)
INTEGRATED MOTOR, NO GEARHEAD



Motor Ready Open (MRO)
READY TO ACCEPT MOTOR/GEARHEAD

Output Plate Bolt Circle Diameters
150 mm, 250 mm, 350 mm, 550 mm

Peak Output Torque
119 Nm to 1148 Nm

Positional Accuracy
 ± 20 to ± 59 ArcSec

Max Backlash
0 to 20.3 ArcSec

Input to Output Ratio
6.2:1 to 2460:1

Sealed Housing Available
IP 65 Rated

PRD: CAPACITY EVEN FOR THE MOST DEMANDING



High Precision Planetary
FLEXIBLE GEARHEAD RATIO

Output Plate Bolt Circle Diameters
400 mm, 750 mm, 1100 mm, 1500 mm

Peak Output Torque
832 Nm to 2860 Nm

Positional Accuracy
 ± 11 to ± 35 ArcSec

Max Backlash
3 to 12 ArcSec

Input to Output Ratio
25.6:1 to 6600:1

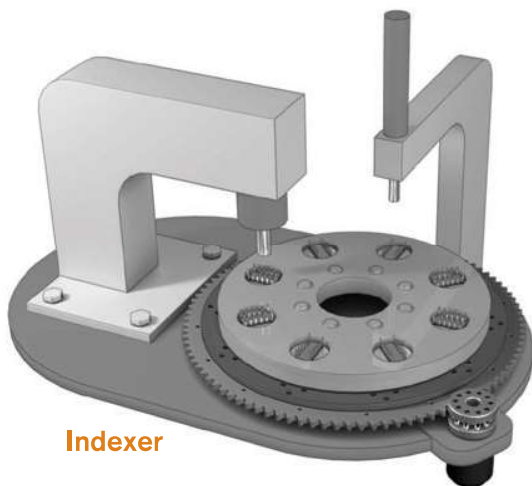

Indexer

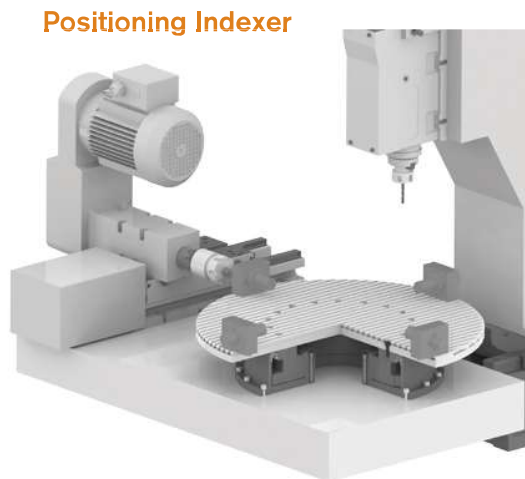

Positioning Indexer



DEPENDABLE. RELIABLE.
PERFORMANCE

Ring Drive Selection Process

Nexen will work with you to select the perfect Ring Drive for your application needs. Please fill in the application data below and perform the calculations on the following page. With this information, Nexen will select a Ring Drive system to meet all your application requirements.

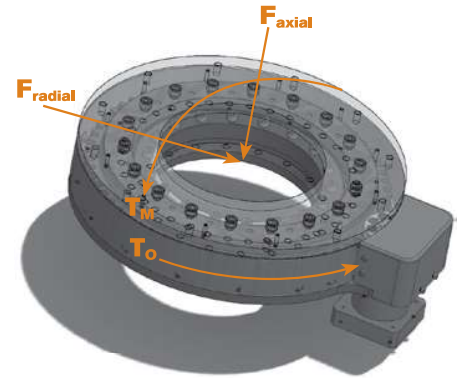

STEP 1: GATHER APPLICATION DATA

Before you begin calculations, there are key measurements that you will need from your application. Collect the data and record it in the chart below. With this data available you can proceed on to the calculations on the following page. (Refer to the diagram to the right when completing the table below.)

Measurements Required for Selection	Customer Data (record your values below)	Sample Data
Load Inertia (I)	kgm ²	70 kgm ²
Index Time (t_i)	seconds	0.9 seconds
Move Distance (θ)	°	45°
Maximum <i>Dynamic</i> Axial Load (F_{Amax})	kN	50 kN
Maximum <i>Dynamic</i> Radial Load (F_{Rmax})	kN	0 kN
Maximum <i>Dynamic</i> Moment Load (M_{max})	kNm	1 kNm
Maximum Static Axial Load (F_{A0})	kN	20 kN
Maximum Static Radial Load (F_{R0})	kN	0 kN
Maximum Static Moment Load (M₀)	kNm	0.5 kNm
Drag Torque & Other Applied Torque Loads (T_o) May include table support friction, cutting or clamping forces, etc.	Nm	10 Nm
Shock Factor (K) Circle the value that best reflects the smoothness of your application.	Shockless Operation 1.0 Normal Operation 1.2 Operation with Impact 1.5 Operation with High Impact 3.0	1.2

Other Key Application Information

Application Description:

Environmental Conditions: Typical Industrial High Humidity High Temperature High Dust

Positional Accuracy Requirements:

Mounting Orientation: Vertical (Radial Load) Horizontal (Applied Load) Horizontal (Suspended Load)

STEP 2: CALCULATING RING DRIVE REQUIREMENTS FOR SIMPLE INDEXING APPLICATIONS

Ring Drive selection is based on the torque requirements of your application. Using the information gathered on the preceding page, perform the following calculations. If your application movement is more complex than basic indexing, evaluate each stage of movement independently and perform separate calculations for each stage.

ACCELERATION TIME: $t_A = t_i \div 2$		$t_A =$ <input type="text"/> sec $\div 2$	ACCELERATION TIME	$t_A =$ <input type="text"/> sec
<i>Sample: $t_A = 0.9 \text{ seconds} \div 2 = 0.45 \text{ seconds}$</i>				

MAX ANGULAR SPEED:		$\omega =$ (<input type="text"/> ° \cdot <input type="text"/> sec) \cdot ($\pi \div 90$)	MAX ANGULAR SPEED	$\omega =$ <input type="text"/> rad/sec
<i>Sample: $\omega = (45^\circ \div 0.9 \text{ seconds}) \cdot (\pi \div 90) = 1.75 \text{ rad/sec}$</i>				

ANGULAR ACCELERATION: $\alpha = \omega \div t_A$		$\alpha =$ <input type="text"/> rad/sec \div <input type="text"/> sec	ANGULAR ACCELERATION	$\alpha =$ <input type="text"/> rad/s ²
<i>Sample: $\alpha = 1.75 \text{ rad/sec} \div 0.45 \text{ sec} = 3.89 \text{ rad/s}^2$</i>				

APPLICATION TORQUE:		$T_{\text{gear}} =$ (<input type="text"/> kgm ² \cdot <input type="text"/> rad/s ²) $+$ <input type="text"/> Nm	APPLICATION OUTPUT TORQUE	$T_{\text{gear}} =$ <input type="text"/> Nm
<i>Sample: $T_{\text{gear}} = (70 \text{ kgm}^2 \cdot 3.89 \text{ rad/s}^2) + 10 \text{ Nm} = 282.3 \text{ Nm}$</i>				

APPLICATION TORQUE WITH SHOCK FACTOR:		$T_T =$ <input type="text"/> Nm \cdot <input type="text"/>	APPLICATION OUTPUT TORQUE W/ SHOCK FACTOR	$T_T =$ <input type="text"/> Nm
<i>Sample: $T_T = 282.3 \text{ Nm} \cdot 1.2 = 339 \text{ Nm}$</i>				

STEP 3: ADD DRAG TORQUE TO APPLICATION TORQUE

Drag Torque varies based on the load placed on the bearing. Use Page 18-19 (CRD) or Page 30 (PRD) to calculate Total Drag Torque (T_{BD}) for the chosen product & application. Add Total Drag Torque (T_{BD}) to Total Output Torque w/ Shock Factor (T_T) and re-compare to specifications of chosen Ring Drive. This will ensure that your Ring Drive Unit has enough Output Torque Capacity to move your load & overcome any drag torque.

TOTAL DRAG TORQUE	$T_{BD} =$ <input type="text"/> Nm
--------------------------	------------------------------------

TOTAL REQUIRED GEAR TORQUE:		$T_{T_{\text{gear}}} =$ <input type="text"/> Nm $+$ <input type="text"/> Nm	TOTAL OUTPUT TORQUE	$T_{T_{\text{gear}}} =$ <input type="text"/> Nm
<i>Sample: $T_{T_{\text{gear}}} = 339 \text{ Nm} + 548 \text{ Nm} = 887 \text{ Nm}$</i>				
* Sample data is for a CRD				

STEP 4: EVALUATE LOAD CARRYING CAPACITY

Use the data for Maximum Axial Load, Maximum Radial Load, Maximum Moment Load, and Mounting Orientation to evaluate your load carrying needs against the load diagrams on the following pages.

To do this, find the set of charts that represents your mounting orientation, then graph your data in the appropriate charts(s) to ensure that your requirements fall into the shaded area representing load capacity available in that CRD or PRD size and orientation.

(NOTE: The weight of the CRD or PRD is already factored into the load charts.)

STEP 5: CHOOSE YOUR RING DRIVE SIZE

Use the Total Output Torque ($T_{T_{\text{gear}}}$) calculated in Step 3 and the load evaluation from Step 4 to select the Ring Drive size that best fits your application. Review CRD and PRD Specifications to ensure the selected size meets all of your application requirements.

SELECTED CRD OR PRD SIZE	<input type="text"/>
---------------------------------	----------------------



Compact Precision Ring Drive (CRD)

Based on innovative Roller Pinion technology, the CRD system comes complete with a precision grade bearing and drive mechanism in a sealed housing. Freely programmable, the drive design configurations allow the CRD to be optimized for high speed, high torque or both depending on the application. With a 150, 250, 350 or 550 mm output bolt circle diameter and a large open center, users can optimize performance in a small space.

Product Descriptions	8
Specifications	8
Direct Drive Motor	9
Dimensions.....	10
Timing Diagrams	11
Load Diagrams	15
Drag Torque Calculations	18
System Life	20
Accessories: Brake, Dial Plates	21

CRD Product Descriptions

Output Bolt Circle Diameter
Compact Ring Drive
Premium or Non-Hardened Gear
Drive Station Type:
Gearboxes: PL=Planetary, HG=Harmonic Gearhead
Other Drive Stations: DD=Direct Drive Motor, MRS=Motor/Gearbox Ready-Sealed,
MRG= Motor/Gearbox Ready-Guarded, MRO=Motor/Gearbox Ready-Open

Input/Output Ratio
Customer Motor Shaft Diameter
Customer Motor Pilot Diameter
Customer Motor Shaft Length

CRD 250 P, PL, 15.2:1, 24.00, 50.00, 110.00

CRD Specifications

		Performance Specifications														
		Maximum Velocity	Max Continuous Velocity	One-Way Positional Accuracy ⁽³⁾	One Way Repeatability ⁽³⁾	Max Backlash	Max Acceleration Torque	Continuous Stall Torque	Nominal Torque	Gear/Pinion Ratio	Input to Output Ratio	Sealed Housing, IP65 Rated	Unloaded Drag Torque (U _{Load})	Max Load Inertia	Output Inertia	Total Reflected Inertia to Gearbox Output
		RPM	RPM	±ArcSec	±ArcSec	ArcSec	Nm	Nm	Nm				Nm	kgm ²	kgm ²	kgm ²
PL	CRD250P-PL	225	151 ⁽²⁾	59 ⁽¹⁾	7.1	20.3 ⁽¹⁾	494	N/A	323	3.8:1	15.2:1 ⁽²⁾	yes	30	N/A	0.227	0.0182
	CRD350P-PL	161	111 ⁽²⁾	43 ⁽¹⁾	5.2	14.8 ⁽¹⁾	676		442	5.2:1	20.8:1 ⁽²⁾	yes	80		0.782	0.0314
	CRD550P-PL	120	70 ⁽²⁾	27 ⁽¹⁾	3.3	9.4 ⁽¹⁾	1066		697	8.2:1	32.8:1 ⁽²⁾	yes	135		4.600	0.0709
HG	CRD250P-HG	25 ⁽²⁾	18 ⁽²⁾	43	7.1	0	532	N/A	380	3.8:1	190:1 ⁽²⁾	yes	30	N/A	0.227	0.0157
	CRD350P-HG	18 ⁽²⁾	13 ⁽²⁾	31	5.2		728		520	5.2:1	260:1 ⁽²⁾	yes	80		0.782	0.0289
	CRD550P-HG	11 ⁽²⁾	8 ⁽²⁾	20	3.3		1148		820	8.2:1	410:1 ⁽²⁾	yes	135		4.600	0.0684
DD	CRD250P-DD	See Charts	See Charts	41	6.9	0	367	100	N/A	6.2:1	6.2:1	yes	30	50	0.219	0.00864 ⁽⁴⁾
	CRD350P-DD			30	5.1		497	136		8.4:1	8.4:1	yes	80		0.761	0.0138 ⁽⁴⁾
	CRD550P-DD			20	3.2		770	210		13:1	13:1	yes	135		4.480	0.0294 ⁽⁴⁾
MRS	CRD150P-MRS	304	222	59	9.8	0	288	N/A	158	9:1	9:1	yes	10	N/A	0.048	0.00091
	CRD250P-MRS	225	160	42	7.1		400		220	12.5	12.5	yes	30		0.194	0.00156
	CRD350P-MRS	161	117	31	5.2		544		299	17:1	17:1	yes	80		0.669	0.00263
MRG	CRD150P-MRG	304	222	59	9.8	0	288	N/A	158	9:1	9:1	no	3	N/A	0.048	0.00091
	CRD250P-MRG	225	160	42	7.1		400		220	12.5	12.5	no	10		0.194	0.00156
	CRD350P-MRG	161	117	31	5.2		544		299	17:1	17:1	no	15		0.669	0.00263
MRO	CRD150N-MRO	304	222	59	9.8	0	119	N/A	119	9:1	9:1	no	3	N/A	0.048	0.00091
	CRD250N-MRO	225	160	42	7.1		165		165	12.5:1	12.5:1	no	10		0.194	0.00156
	CRD350N-MRO	161	117	31	5.2		224		224	17:1	17:1	no	15		0.669	0.00263

(1) Includes Gearbox Backlash (2) Assumes Planetary Gearbox Ratio of 4:1 and Harmonic Gearhead Ratio of 50:1 (other ratio options available)
(3) Contact Nexen for higher precision options (4) Total Reflected Rotary Inertia, including Motor Inertia

CRD Direct Drive Specifications

Peak Speed Torque Curves at Output

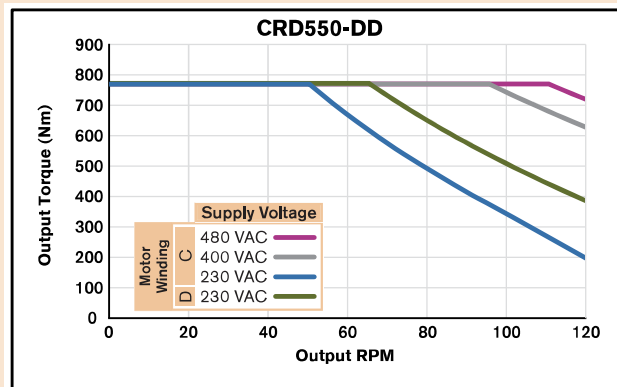
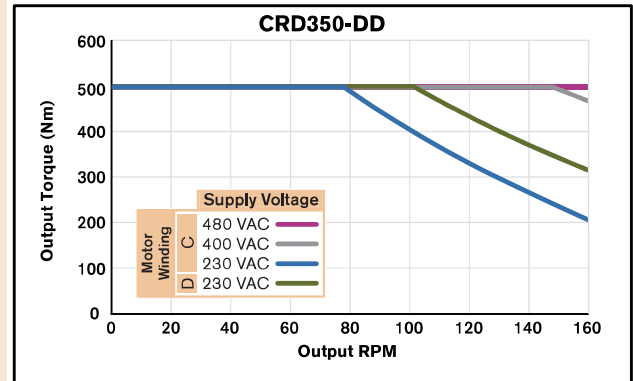
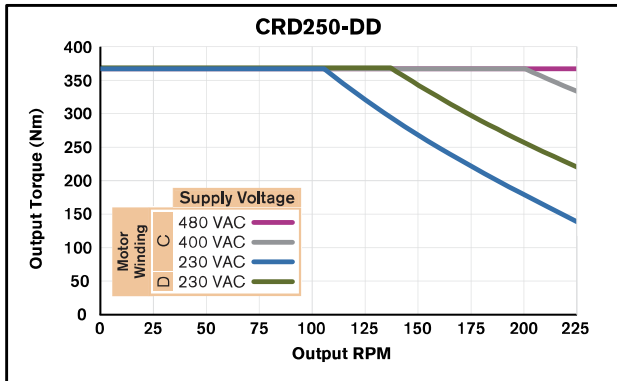

* For non-cyclic continuous operation, contact Nexen.

* Other winding options available, contact Nexen.

CRD Direct Drive Motor Specifications

Direct Drive Motor Specifications

Specifications		CRD250-DD		CRD350-DD		CRD550-DD	
		C	D	C	D	C	D
Motor Winding Selection		C	D	C	D	C	D
Peak Current (I_p) ⁽¹⁾	Arms	39.2	49.5	39.2	49.5	39.2	49.5
Continuous Stall Current (I_c) ⁽²⁾	Arms	7.9	9.8	7.9	9.8	7.9	9.8
Torque Sensitivity (K_t) ⁽³⁾	Nm/Arms	12.7	10.2	17.2	13.7	26.65	21.3
Back EMF Constant (K_b) ⁽³⁾	Vrms/kRPM	769	613	1040	830	1612	1286
Resistance (Line to Line) (R_m)	Ohms	1.80	1.14	1.80	1.14	1.80	1.14
Inductance (L_m)	mH	15	9.3	15	9.3	15	9.3
Motor Poles		10	10	10	10	10	10

(1) @ 25°C winding temperature (2) Winding temperature = 145°C @ continuous stall, 25°C ambient (3) System Equivalent Values

Motor Feedback

CRD Feedback Specifications	ENDAT01
Output Interface	Endat 2.1 Multi-turn
Device Resolution Cycles or Lines/Rev	2048
Resolution after AKD Interpolation Counts	134, 217, 728
Input Voltage VDC ±5%	5
Current Consumption mA Max	250
Plug and Play Motor ID *	Yes

* These feedback devices include electronic motor nameplate data allowing plug-and-play commissioning, eliminating the need for drive parameter set-up and servo loop tuning in most applications.

CRD Dimensions

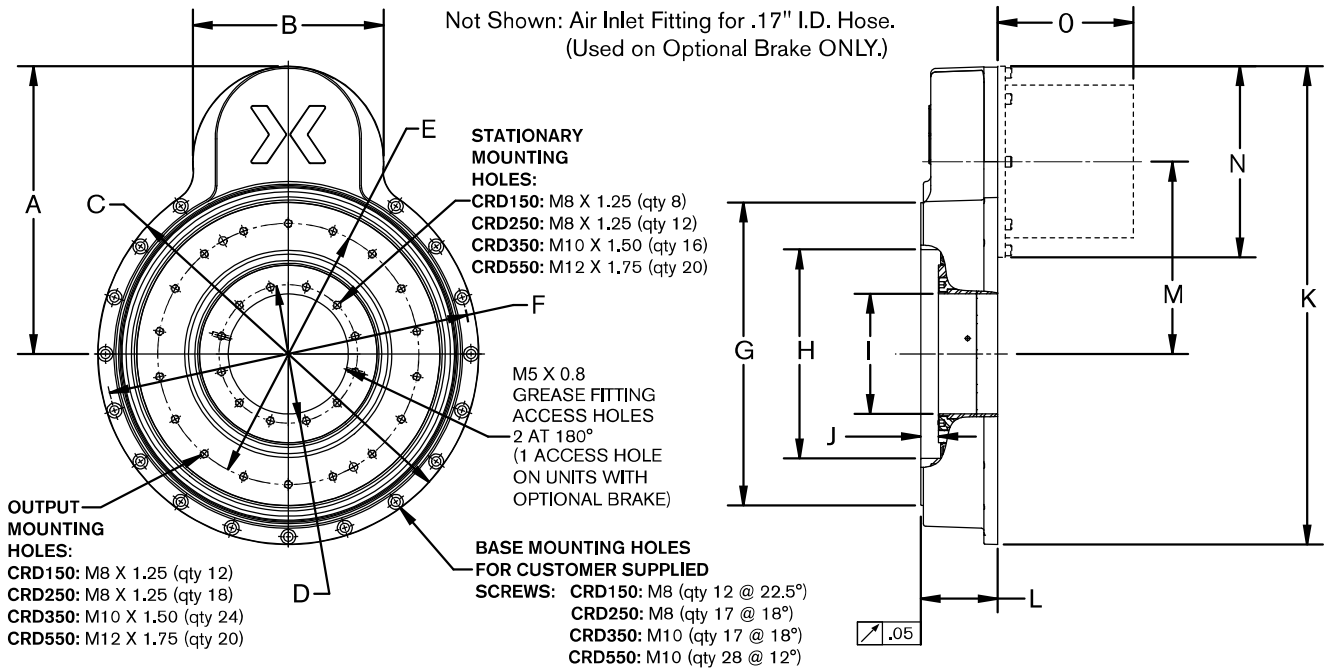

NOTE: Basic dimensions shown for selection purposes only and subject to change. Visit www.nexengroup.com for detailed drawings and CAD models before designing into your system.

			CRD150	CRD250	CRD350	CRD550	
A	Drive Station Envelope to Center Distance	mm	212.5	275.5	329.5	441.5	
B	Drive Station Envelope Width	mm	184.9	182.8	184.3	179.8	
C	Outer Diameter	mm	285	370	488	721.6	
D	Stationary Bolt Circle Diameter *	mm	70	132.5	180	375	
E	Output Bolt Circle Diameter	mm	150	250	350	550	
F	Base Mounting Hole Circle Diameter	mm	265	350	465	698	
G	Output Outer Diameter	mm	199.5	290	385	600	
H	Output Inner Diameter (H7)	mm	120	200	280	470	
I	Inner Diameter	without Brake	mm	45	115	155	350
		with Brake	mm	N/A	31.7	N/A	N/A
J	Depth to Stationary Ring	mm	33.8	16.8	10	7.5	
K	Overall Length	mm	355	457.2	573.4	800.5	
L	Unit Height	mm	73.5	73.5	73.5	84.5	
M	Drive Station Center to CRD Center	PL, HG	mm	N/A	184	238	350
		DD	mm	N/A	174	228	340
		MRS, MRG, MRO	mm	120	162	215	N/A
N	Drive Station & Adapter Width	PL, HG	mm	N/A	183	183	183
		DD	mm	N/A	193	193	193
		MRS, MRG, MRO	mm	185	185	185	N/A
O	Drive Station Depth	PL	mm	N/A	130	130	130
		HG	mm	N/A	58.5	58.5	58.5
		DD	mm	N/A	191	191	191
		MRS, MRG, MRO	mm	59.5	59.5	59.5	N/A

* Not present on units with optional brake.

CRD150 Timing Diagrams

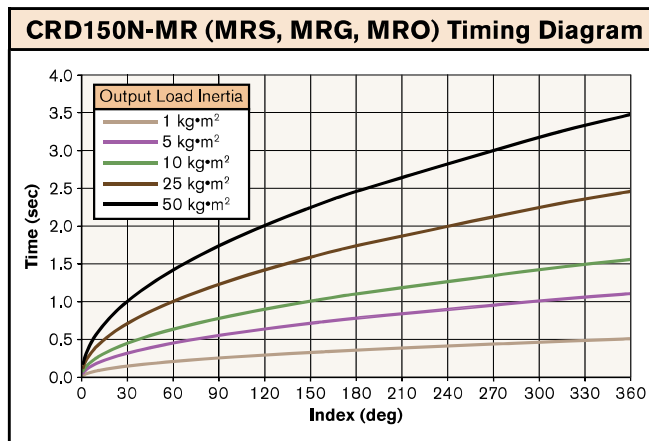
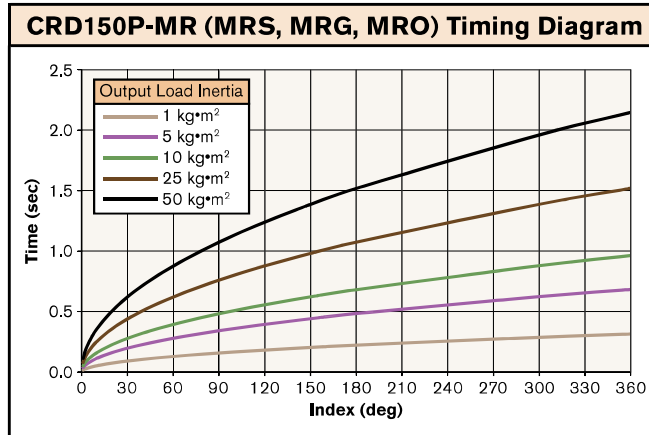

NOTES: Curves assume no external forces such as additional table support friction, cutting forces, etc.
Timing diagrams are developed assuming minimum drag torque, use for reference only.

*Assumes Planetary Gearbox Ratio of 4:1 and Harmonic Gearhead Ratio of 50:1 (other ratio options available)

CRD250 Timing Diagrams

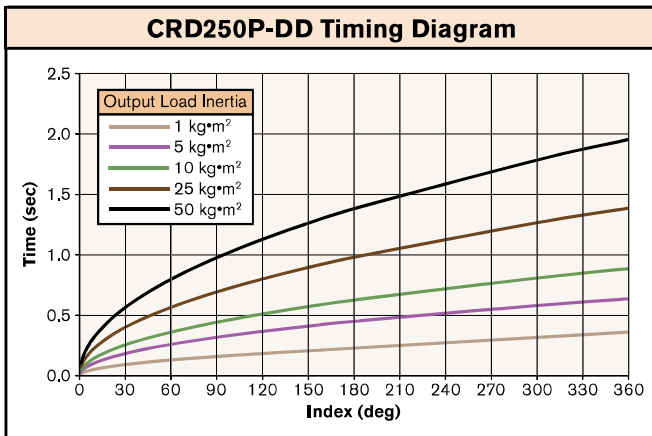
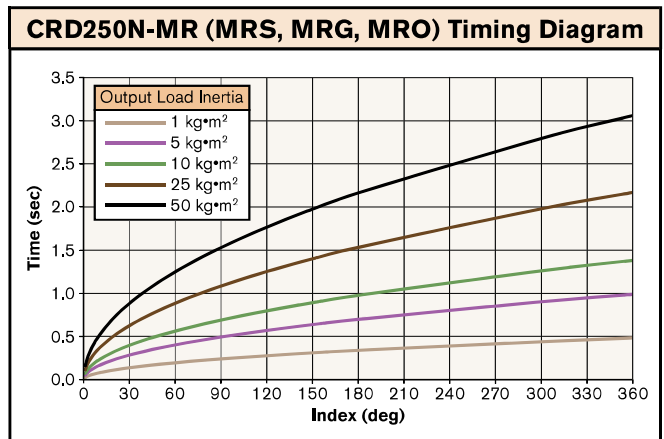
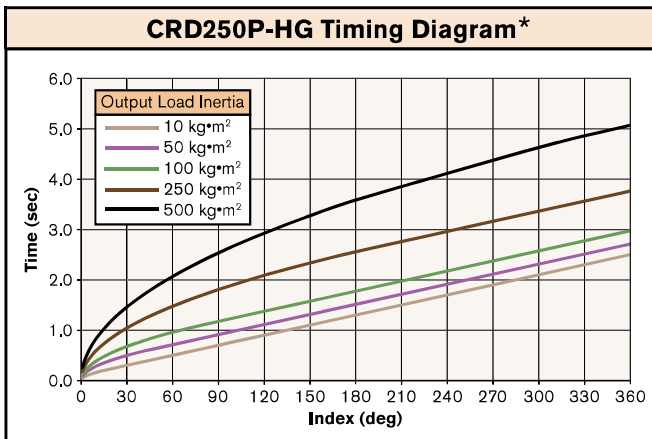
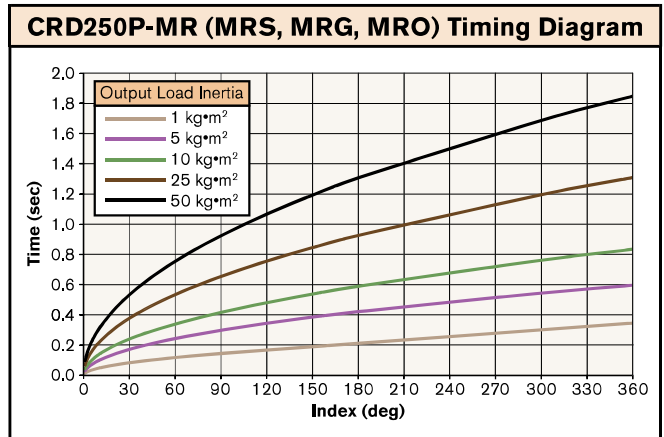
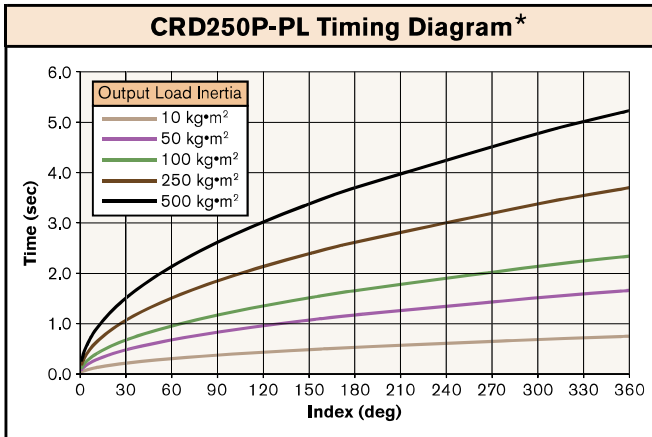

NOTES: Curves assume no external forces such as additional table support friction, cutting forces, etc.
Timing diagrams are developed assuming minimum drag torque, use for reference only.

*Assumes Planetary Gearbox Ratio of 4:1 and Harmonic Gearhead Ratio of 50:1 (other ratio options available)

CRD350 Timing Diagrams

CRD350P-PL Timing Diagram*

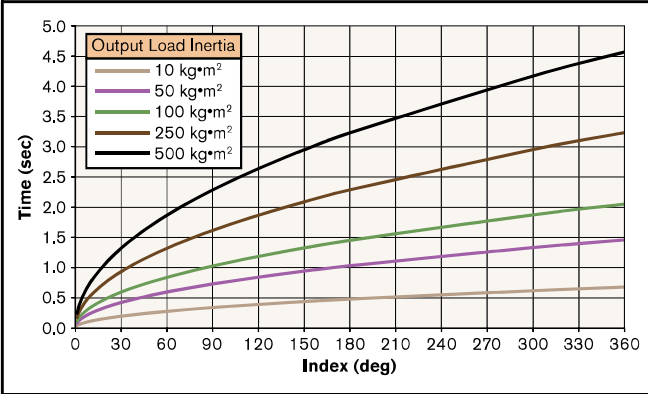

CRD350P-MR (MRS, MRG, MRO) Timing Diagram

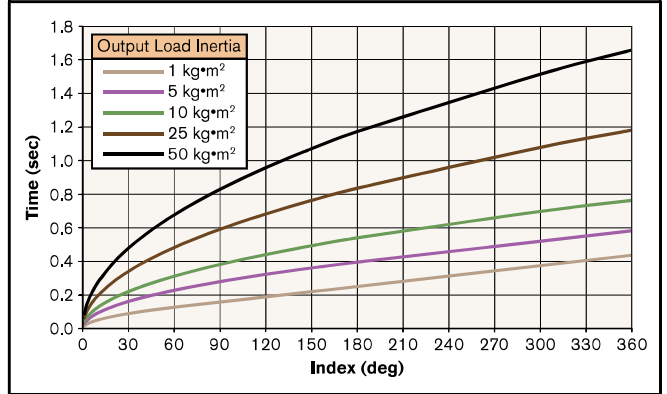

CRD350P-HG Timing Diagram*

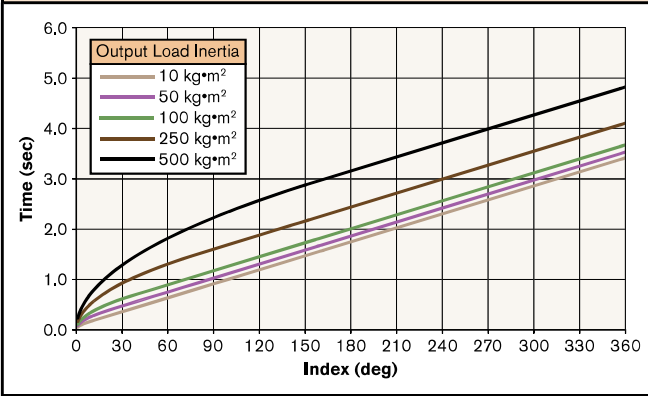

CRD350N-MR (MRS, MRG, MRO) Timing Diagram

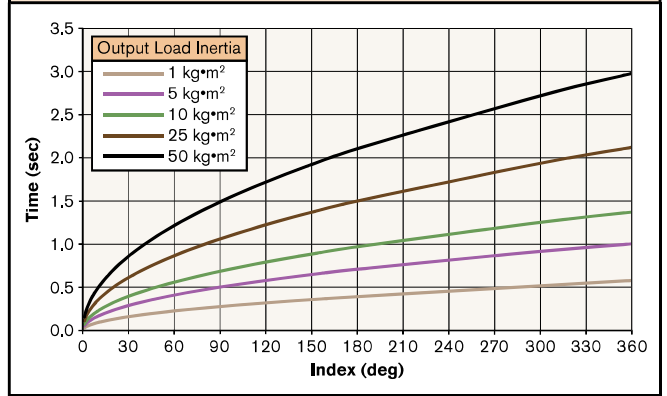

CRD350P-DD Timing Diagram

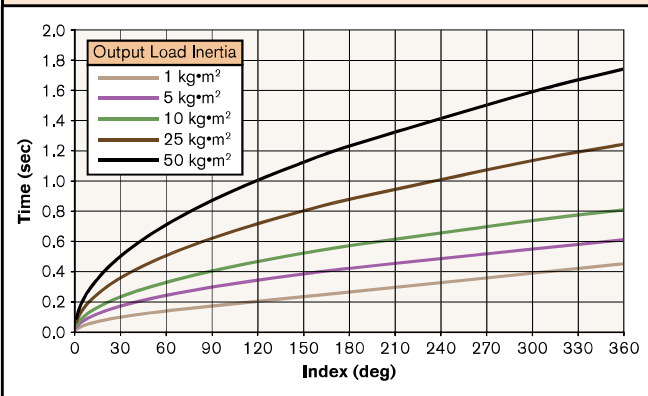

NOTES: Curves assume no external forces such as additional table support friction, cutting forces, etc.
Timing diagrams are developed assuming minimum drag torque, use for reference only.

*Assumes Planetary Gearbox Ratio of 4:1 and Harmonic Gearhead Ratio of 50:1 (other ratio options available)

CRD550 Timing Diagrams

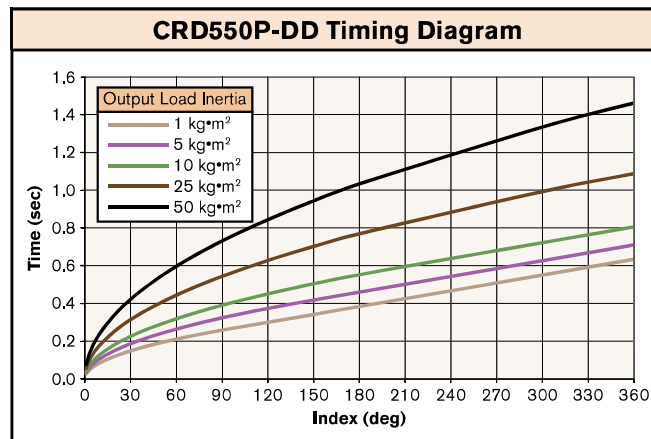
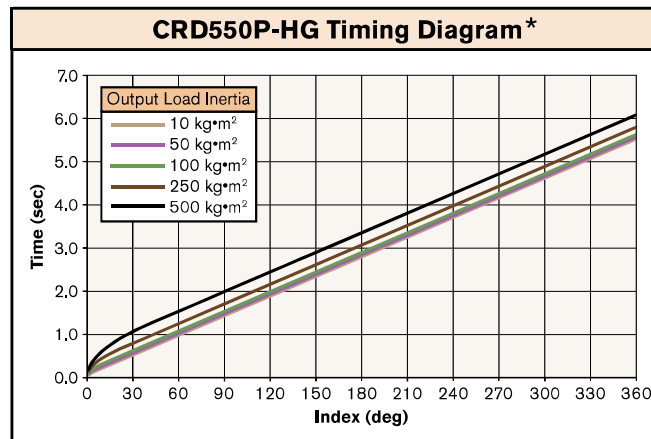
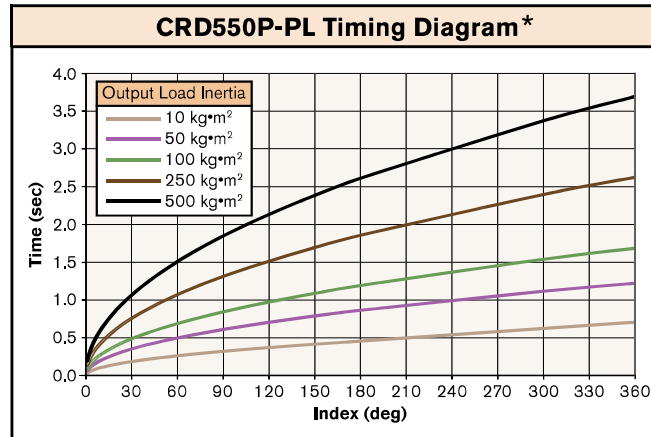

NOTES: Curves assume no external forces such as additional table support friction, cutting forces, etc. Timing diagrams are developed assuming minimum drag torque, use for reference only.

*Assumes Planetary Gearbox Ratio of 4:1 and Harmonic Gearhead Ratio of 50:1 (other ratio options available)

CRD Load Diagrams (Applied Load)

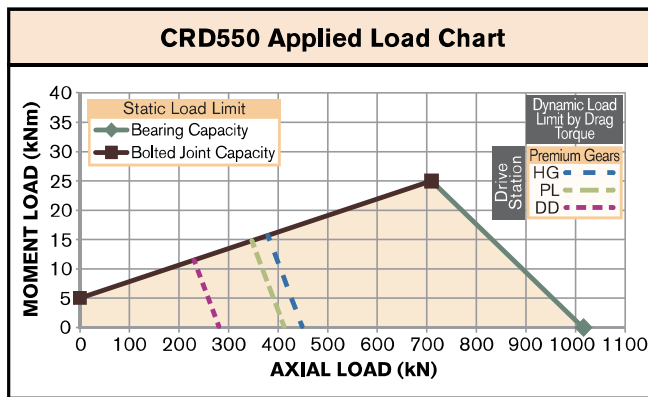
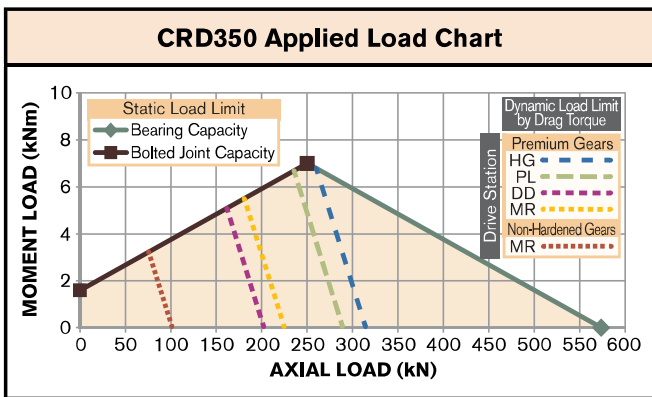
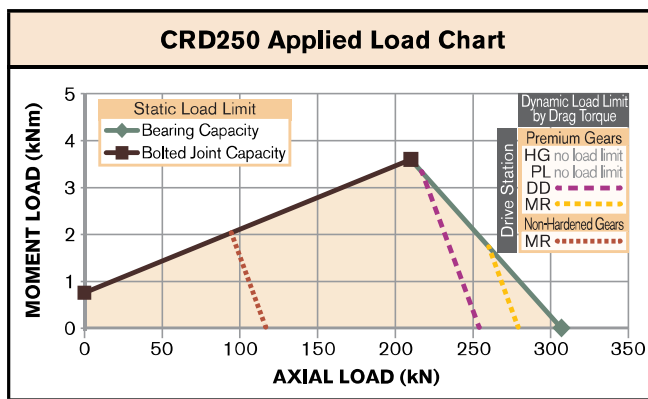
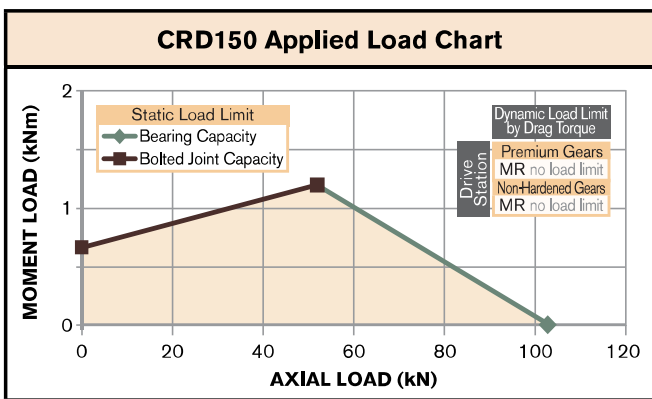
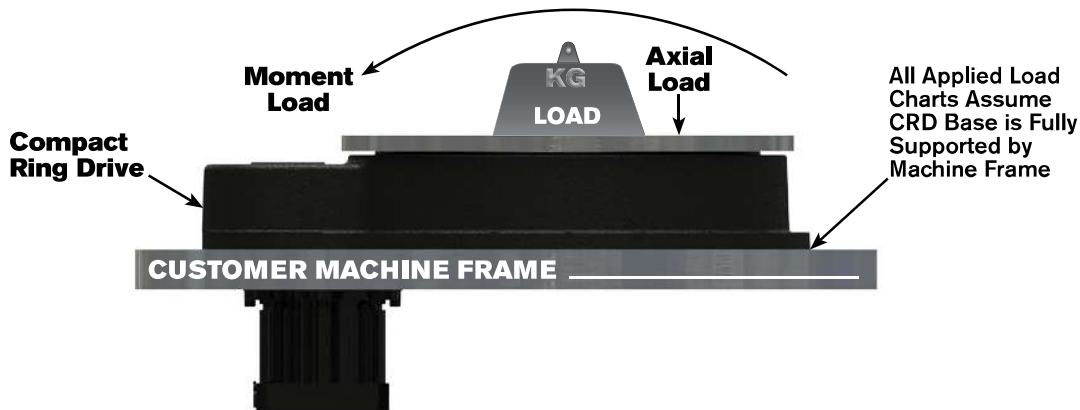

Contact Nexen for bearing life in this orientation

CRD Load Diagrams (Suspended Load)

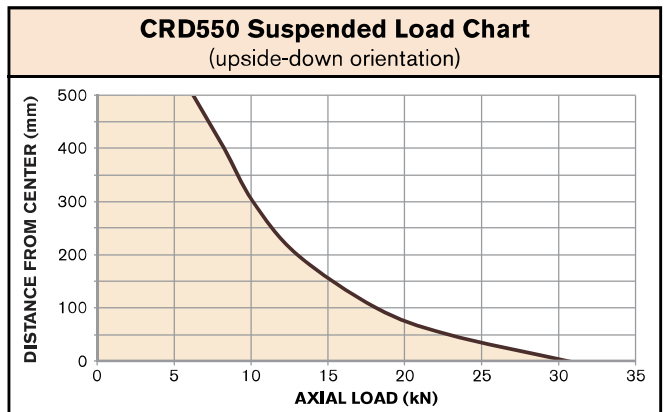
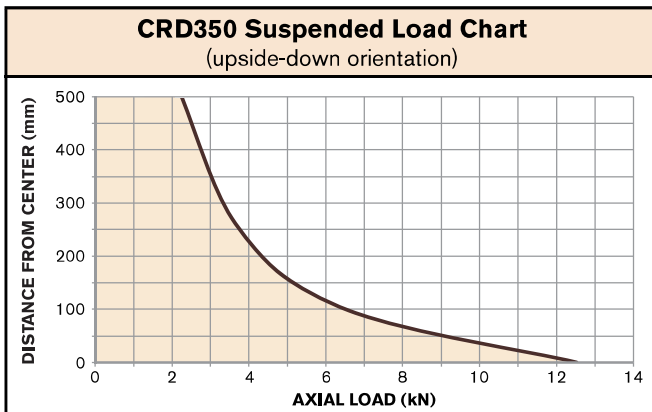
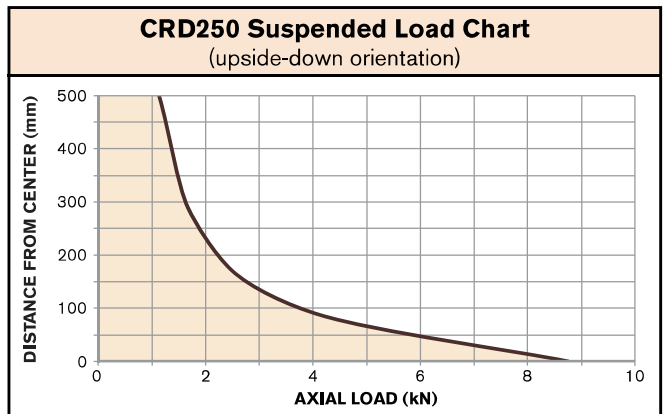
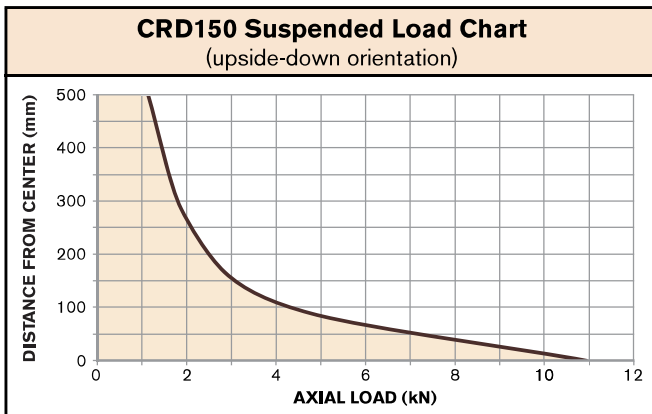
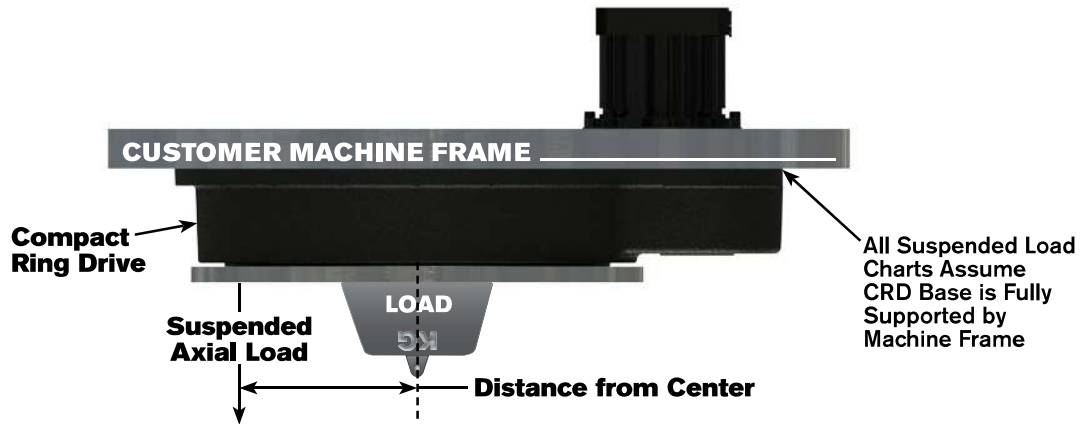

NOTE: There are no Dynamic Load Limits by Drag Torque, for Suspended Loads

CRD Load Diagrams (Radial Load)

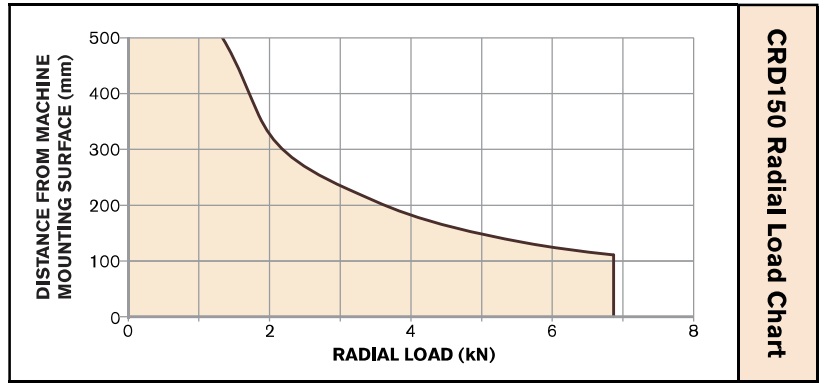
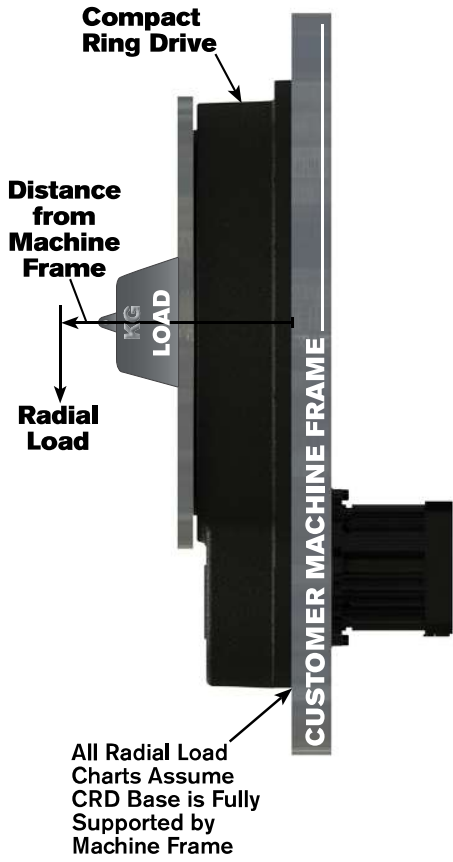

CRD150 Radial Load Chart

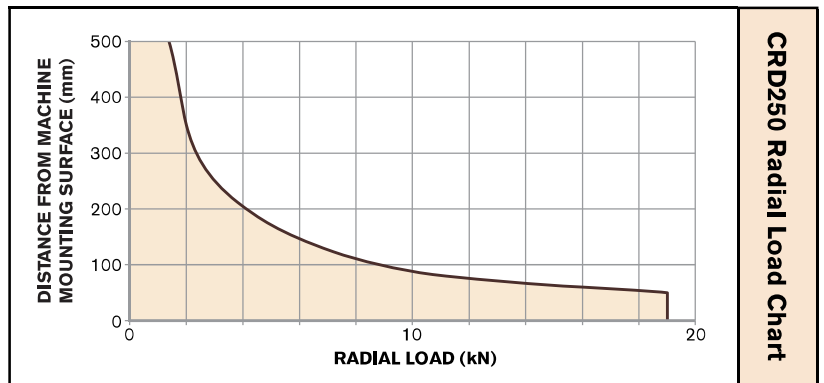

CRD250 Radial Load Chart

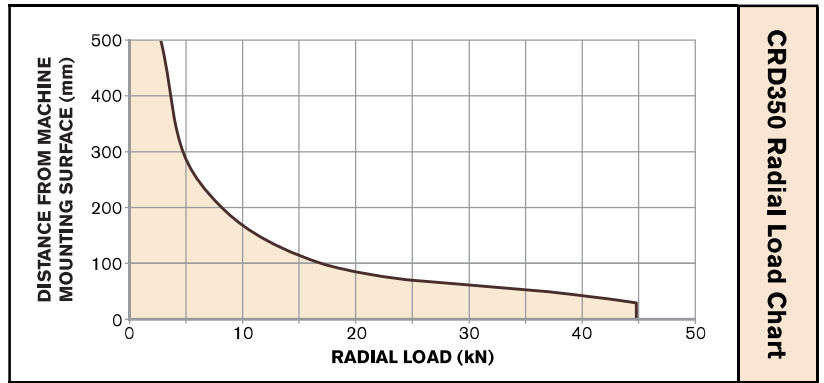

CRD350 Radial Load Chart

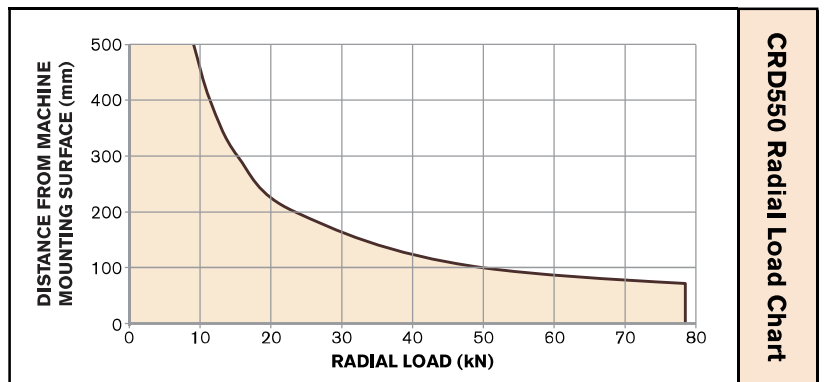

CRD550 Radial Load Chart

NOTE: There are no Dynamic Load Limits by Drag Torque, for Radial Loads

CRD Drag Torque Calculations

Drag Torque varies based on the load placed on the bearing. Use the calculations below to find the Drag Torque for your application.

STEP 1: GATHER APPLICATION DATA

Before you begin calculations, there are several key measurements that you will need from your application in order to calculate drag torque. Collect the data and record it in the space provided.

Measurements for Bearing Calculations	Customer Data (record your values below)	Sample Data*
Maximum Dynamic Gear Torque of Application (T_{maxApp})	Nm	339 Nm
Maximum Dynamic Radial Load (F_{Rmax})	N	0 N
Maximum Dynamic Axial Load (F_{Amax})	N	200,000 N
Maximum Dynamic Moment Load (M_{max})	Nm	500 Nm
Unloaded Drag Torque of CRD (U_{Ldrag})	Nm	135 Nm
From CRD Specs		

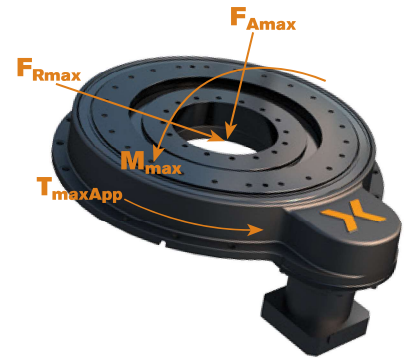

*Sample data is for a CRD550-PL (load data was based on a specific application)

Bearing Race Specific Data

Bearing Size		CRD150	CRD250	CRD350	CRD550	
Basic Dynamic Load Rating (C)		N	31,400	80,300	151,000	206,000
Basic Static Load Rating (C ₀)		N	45,300	135,000	252,000	447,000
Rolling Diameter of Cross Roller (dp)		m	0.108	0.178	0.248	0.453
RPS Generated Load Factor (K_{rps})	RPS16 [CRD-DD]	m ⁻¹	N/A	7.88	5.34	3.67
	RPS25 [CRD-PL & CRD-HG]	m ⁻¹	N/A	7.19	5.81	3.63
	RPS1306 [CRD-MRS, CRD-MRG & CRD-MRO]	m ⁻¹	11.25	8.30	6.21	N/A

STEP 2: CALCULATE THE MAXIMUM DYNAMIC EQUIVALENT RADIAL LOAD

Perform the following calculations using the data from the Table above and your application data from STEP 1.

Loading Distribution	IF:	THEN:	
		X	Y
$\frac{F_{Amax}}{F_{Rmax} + \frac{2 * M_{max}}{dp} + T_{maxApp} * K_{rps}}$	≤ 1.5	1	0.45
$\frac{F_{Amax}}{F_{Rmax} + \frac{2 * M_{max}}{dp} + T_{maxApp} * K_{rps}}$	> 1.5	0.67	0.67

MAXIMUM DYNAMIC EQUIVALENT RADIAL LOAD:

$$P_{Cmax} = X * \left(F_{Rmax} + \left(\frac{2 * M_{max}}{dp} \right) + (T_{maxApp} * K_{rps}) \right) + (Y * F_{Amax})$$

$$P_{Cmax} = \text{ } * \left(\text{ } N + \frac{2 * \text{ } Nm}{\text{ } m} + \left(\text{ } Nm * \text{ } m^{-1} \right) \right) + \left(\text{ } * \text{ } N \right)$$

MAXIMUM DYNAMIC EQUIVALENT RADIAL LOAD

$$P_{Cmax} = \text{ } N$$

Sample: $P_{Cmax} = 0.67 * \left(0 N + \frac{2 * 500 Nm}{0.453 m} + \left(339 Nm * 3.61 m^{-1} \right) \right) + \left(0.67 * 200,000 N \right) = 136,298 N$

CRD Drag Torque Calculations

STEP 3: DETERMINE BEARING DRAG TORQUE

The bearing drag torque can be estimated based on the dynamic equivalent radial load. Use the following charts to determine your approximate bearing drag torque.

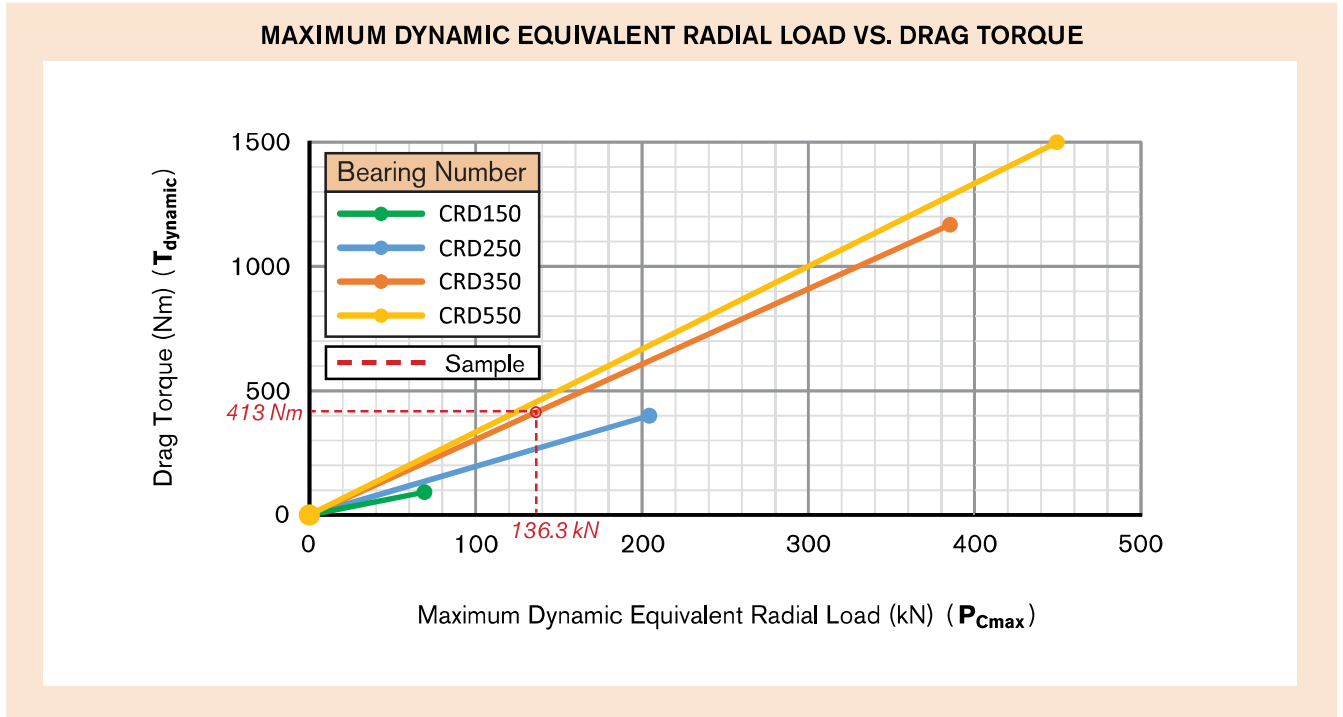

CRD TOTAL DRAG TORQUE:

$$T_{BD} = T_{Dynamic} + U_{Ldrag}$$

CRD TOTAL DRAG TORQUE

$$T_{BD} = \text{Nm} + \text{Nm} \quad T_{BD} = \text{Nm}$$

Sample: $T_{BD} = 413 \text{ Nm} + 135 \text{ Nm} = 548 \text{ Nm}$

STEP 4: COMPLETE OUTPUT TORQUE CALCULATIONS

Refer to the worksheet on Page 5 of Ring Drive Selection Process to calculate the Total Output Torque required for your application.

CRD System Life

CRD life is based on average output torque and drive station options.

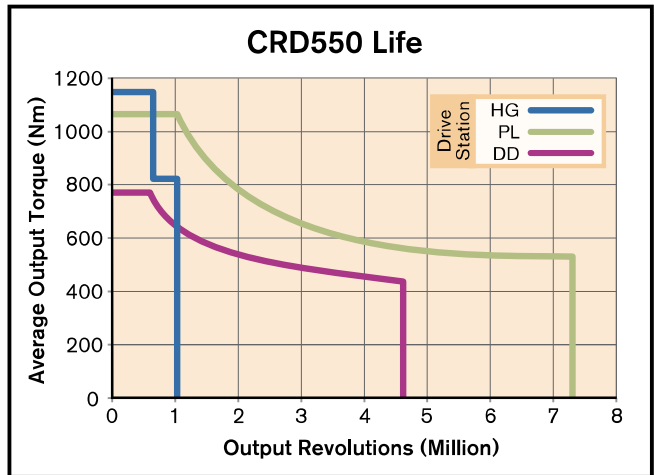
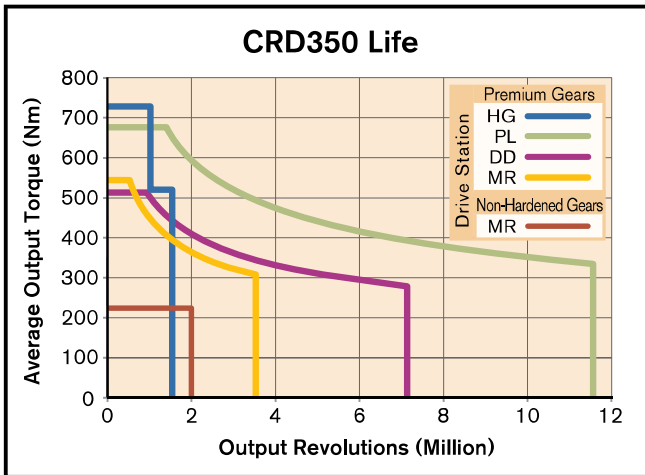
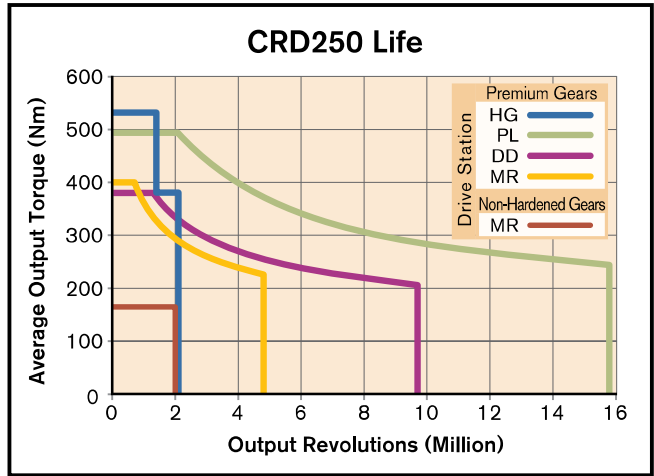
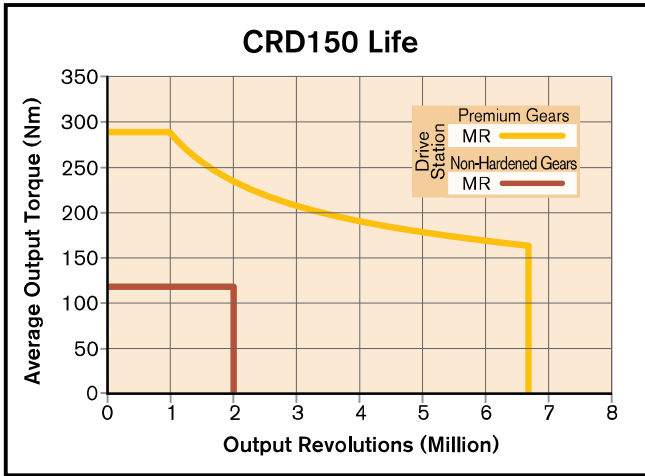

Assumes Planetary Gearbox Ratio of 4:1 and Harmonic Gearhead Ratio of 50:1 (other ratio options available)

CRD Accessories: Brake

Optional Holding Brake

Nexen offers an optional holding brake that acts directly on the CRD driven output. (Available on CRD250, other sizes pending.) With spring engaged / air released braking action, the brake's compact design does not increase the CRD footprint and maintains an open center. For brake E-Stop capabilities, contact Nexen.



Brake Specifications		CRD250, BRAKE
Holding Torque	Nm	800
Release Pressure	psi	60
Brake Life	Cycles	1 million
Brake Torsional Rigidity	Nm / Radian	8.65 million

Note: Brake can be manually released by inserting screws into holes on its bottom side.

Note: Brake is fully sealed and IP 65 rated.

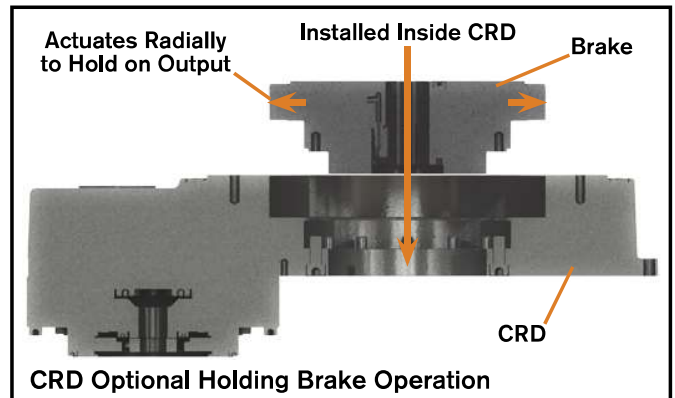

CRD Accessories: Dial Plates

Optional Dial Plates

Nexen offers customizable dial plates that precisely pilot on the output of Nexen Ring Drives. Contact Nexen to customize these plates for your application.

	Standard Dial Plate Thickness	Standard Dial Plate Outer Diameter		
		550mm [21.65"]	900mm [35.43"]	1350mm [53.15"]
CRD150	19.05mm [0.75"]	967900	967901	N/A
CRD250		967903	967904	967905
CRD350		967906	967907	967908
CRD550		N/A	967909	967910

Contact Nexen to customize dial plate. Visit www.nexengroup.com

Common Customizations:

- ✓ Open Center
- ✓ Hole Patterns
- ✓ Pilots
- ✓ Cutouts
- ✓ Plate Diameter

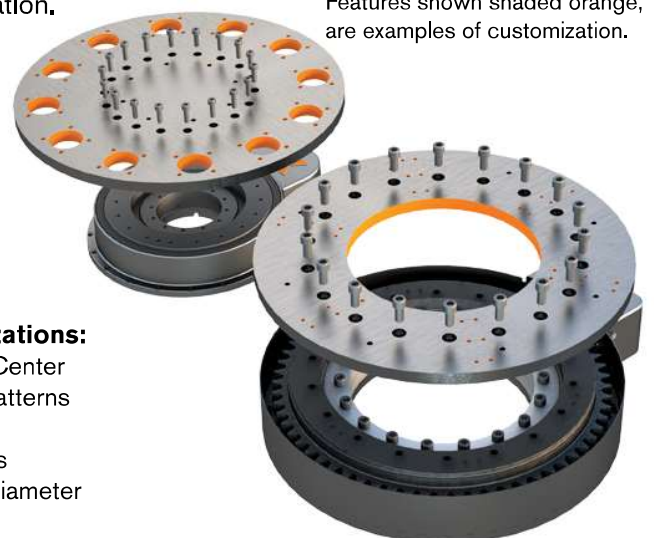

*Features shown shaded orange, are examples of customization.



Precision Ring Drive (PRD):

The PRD system offers all the great features of our other advanced RPS technology and opens up new design possibilities to next generation machines. PRD table is supported by a high capacity crossroller bearing rated for loads up to 1575 kN. Peak torque inputs at any time allows for indexing times up to 2x faster than the competition.

Product Descriptions	24
Specifications	24
Dimensional Drawing	25
Timing Diagrams	26
Load Diagrams	27
Bearing Drag Torque Calculations	30
Accessories: Dial Plates, Guarding	31

PRD Product Descriptions

Approximate Output Bolt Circle Diameter
 Precision Ring Drive
 Input/Output Ratio

PRD 400, 64:1, 19.00, 55.00, 110.00

Customer Motor Shaft Diameter
 Customer Motor Shaft Length
 Customer Motor Pilot Diameter

(All PRD's Have Premium Gears, and Planetary Gearboxes)

PRD Specifications

Performance Specifications		PRD400	PRD750	PRD1100	PRD1500
Maximum Velocity	RPM	94	54	35	27
Positional Accuracy	±ArcSec	35 ⁽¹⁾	21 ⁽¹⁾	13 ⁽¹⁾	11 ⁽¹⁾
One Way Repeatability	±ArcSec	4.2	2.4	1.6	1.2
Max Backlash	ArcSec	12 ⁽¹⁾	7 ⁽¹⁾	4 ⁽¹⁾	3 ⁽¹⁾
Max Acceleration Torque	Nm	832	1430	2210	2860
Nominal Torque	Nm	544	935	1445	1870
Gear/Pinion Ratio		6.4:1	11:1	17:1	22:1
Input to Output Ratio		25.6:1 ⁽²⁾	44:1 ⁽²⁾	68:1 ⁽²⁾	88:1 ⁽²⁾
Min Drag Torque (no load) (U_{Ldrag})	Nm	40	100	150	200
Output Inertia	kgm ²	1.39	8.83	48.97	112.95
Total Reflected Inertia to Gearbox Output	kgm ²	0.036	0.075	0.172	0.236

⁽¹⁾ Includes Gearbox Backlash

⁽²⁾ Assumes Planetary Gearbox Ratio of 4:1

PRD Dimensions

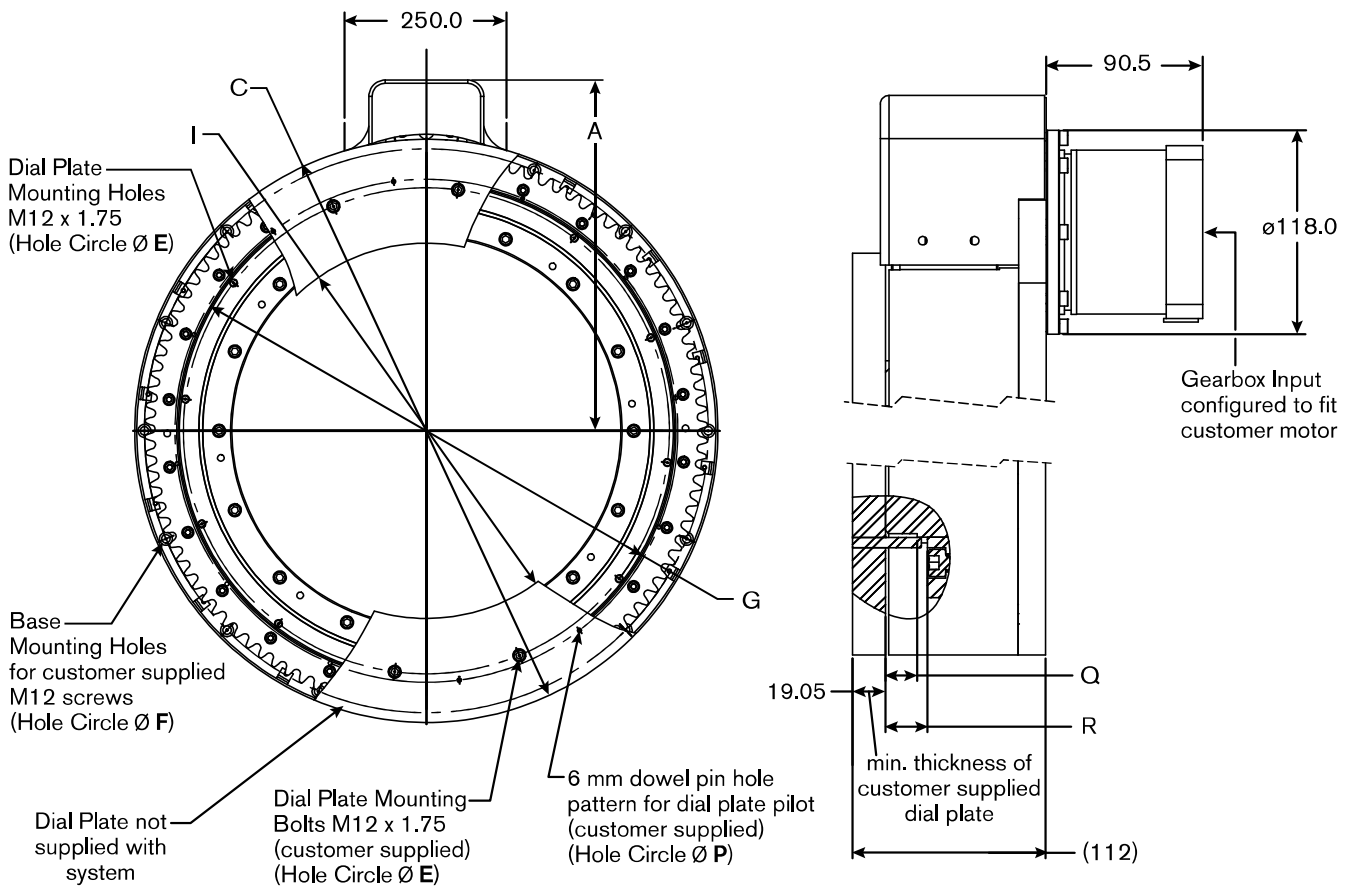

NOTE: Basic dimensions shown for selection purposes only and subject to change. Visit www.nexengroup.com for detailed drawings and CAD models before designing into your system. (All dimensions shown in mm.)

			PRD400	PRD750	PRD1100	PRD1500
A	Drive Station Envelope to Center Distance	mm	363	543	770	970
C	Minimum Outer Diameter	mm	550	900	1350	1750
E	Output Bolt Pattern Circle Diameter	mm	396	750	1100	1500
F	Base Mounting Hole Circle Diameter	mm	500	870	1325	1715
G	Ring Drive Pilot Diameter	mm	460	770	1150	1525
I	Inner Diameter	mm	280	579	966	1330
P	Dowel Pin Hole Circle For 6mm Pins	mm	466	776	1156	1531
Q	Minimum Depth to Dial Plate Pilot	mm	0	18.5	18.5	18.5
R	Maximum Depth to Dial Plate Pilot	mm	7	24.5	24.5	24.5

PRD Timing Diagrams

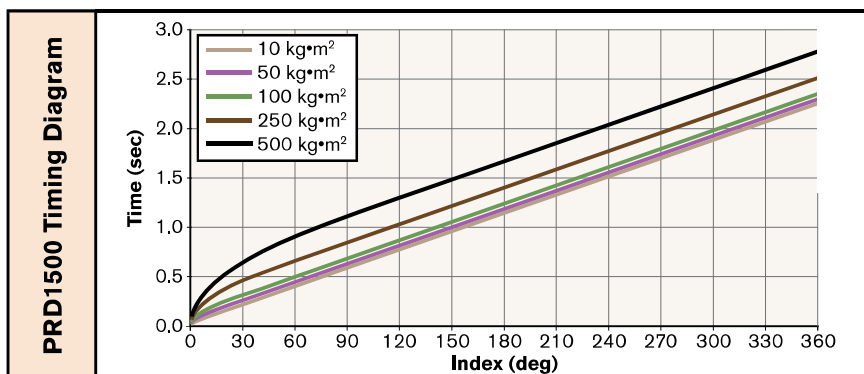
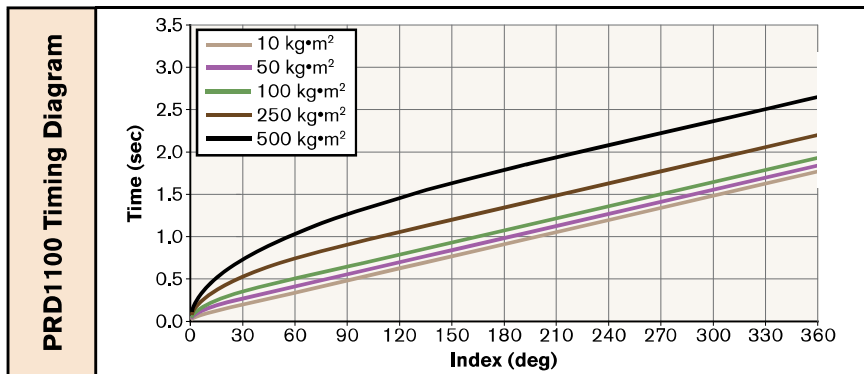
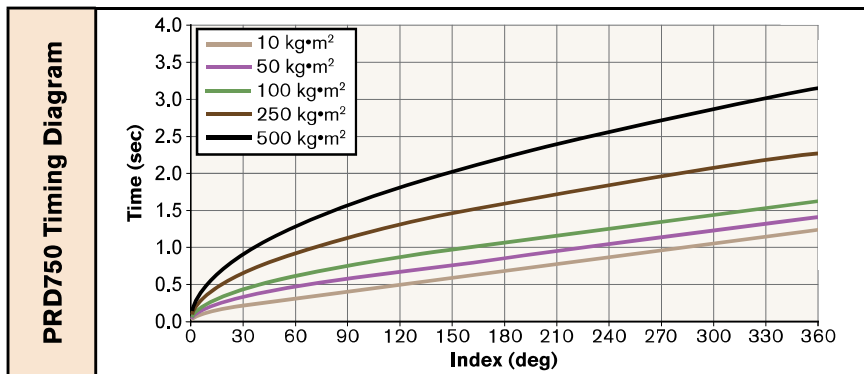
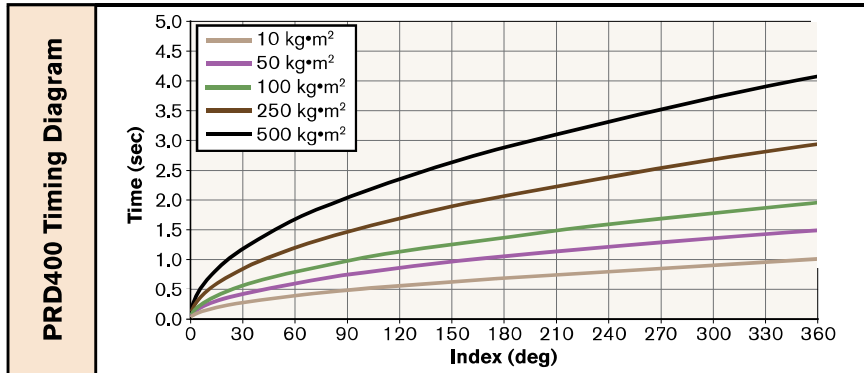

NOTE: Curves assume no external forces such as additional table support friction, cutting forces, etc.

PRD Load Diagrams (Applied Load)

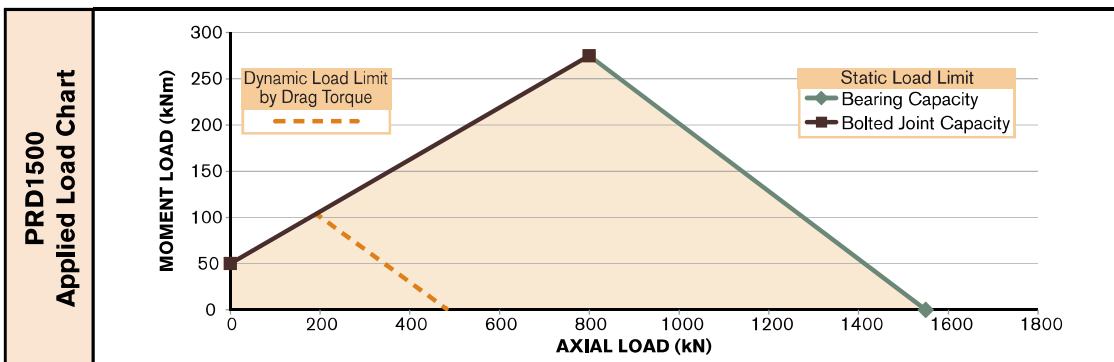
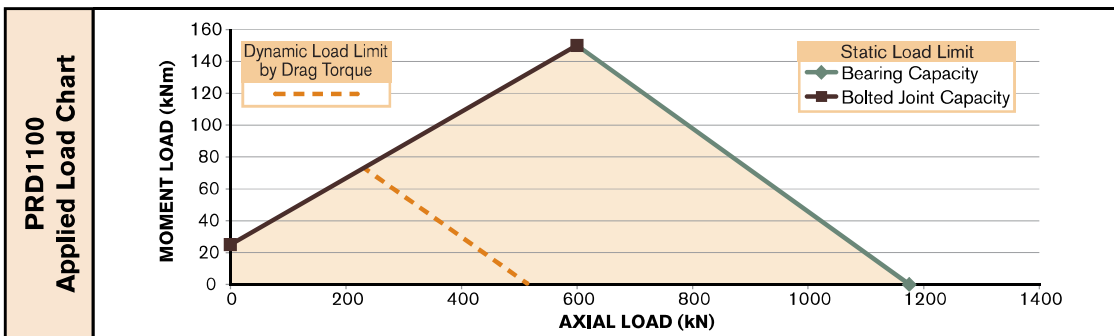
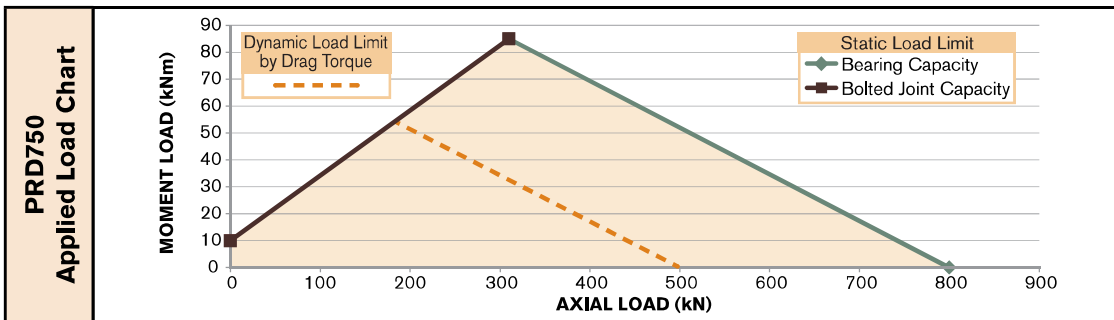
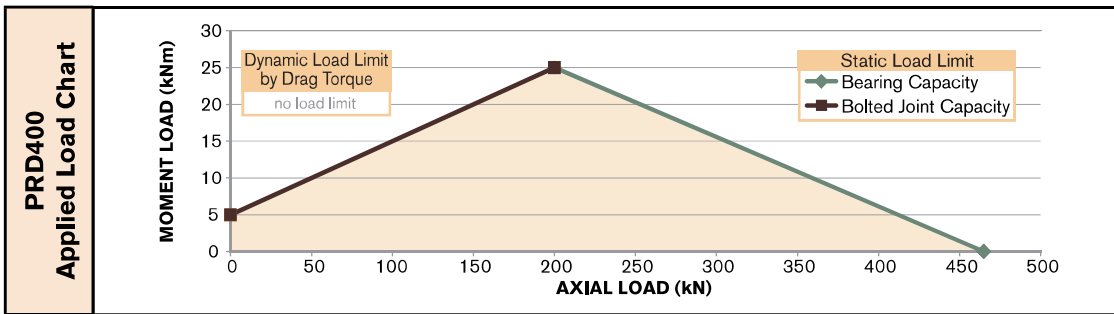
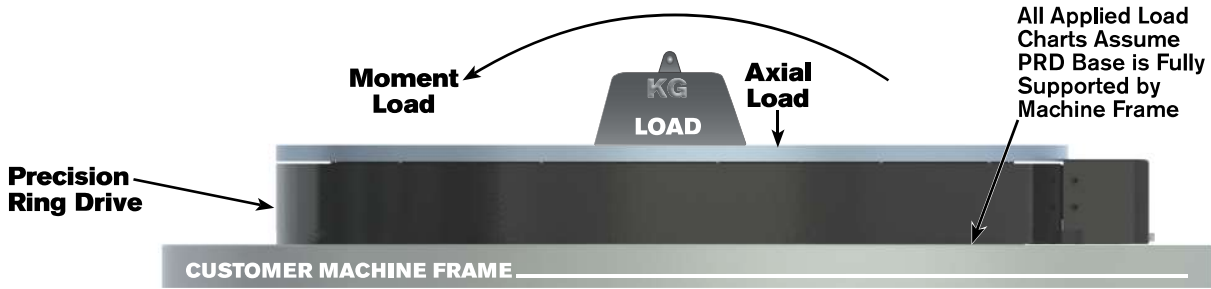

PRD Load Diagrams (Suspended Load)

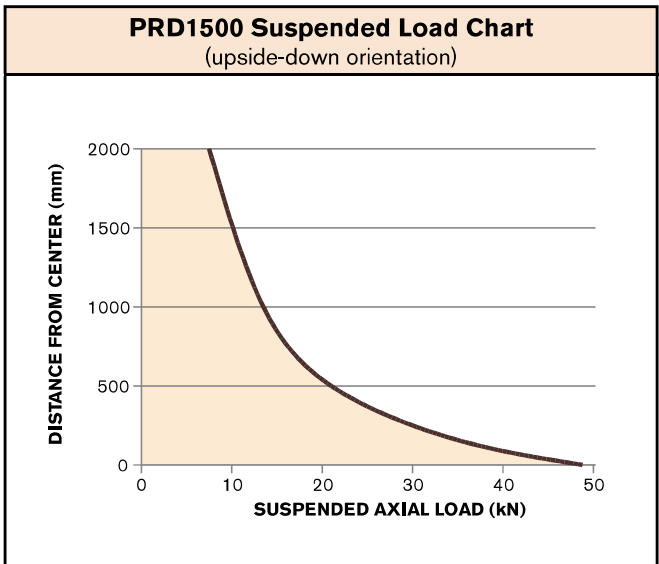
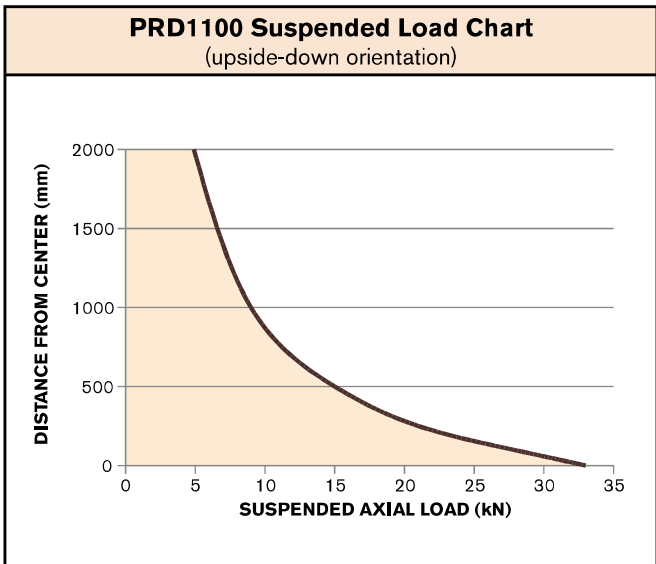
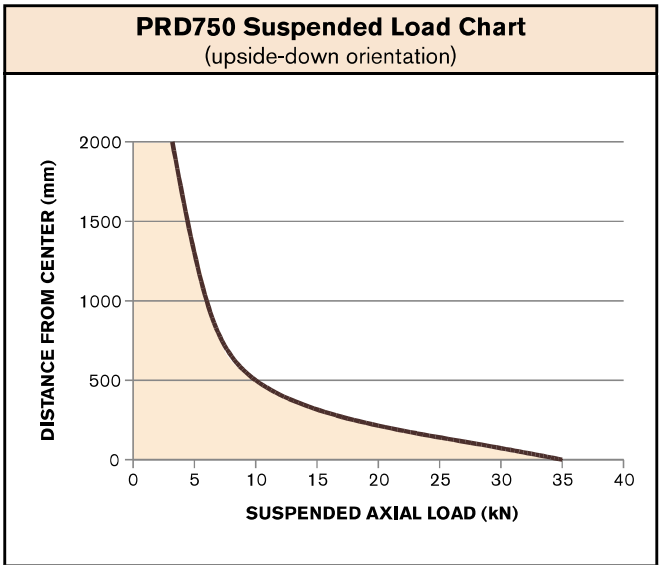
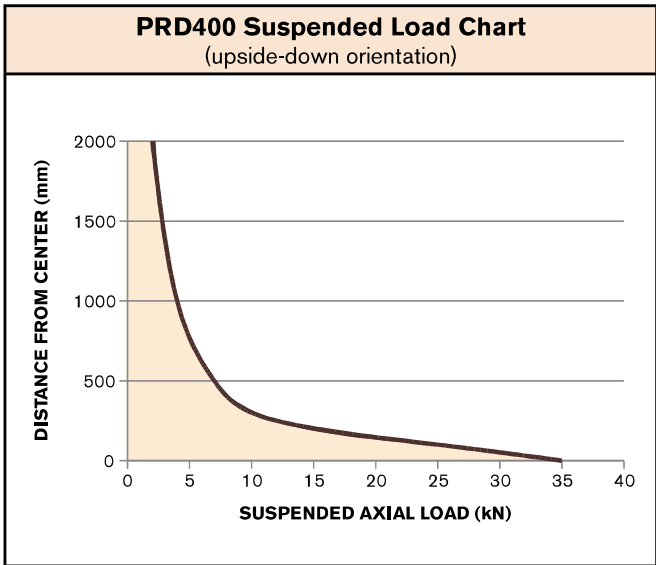
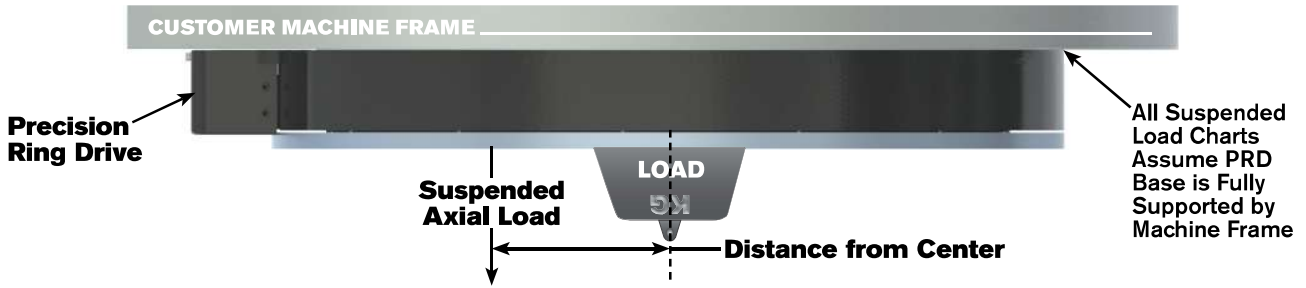

NOTE: The weight of the PRD is already factored into these charts.

NOTE: There are no "Dynamic Load Limits by Drag Torque" for Suspended Loads.

PRD Load Diagrams (Radial Load)

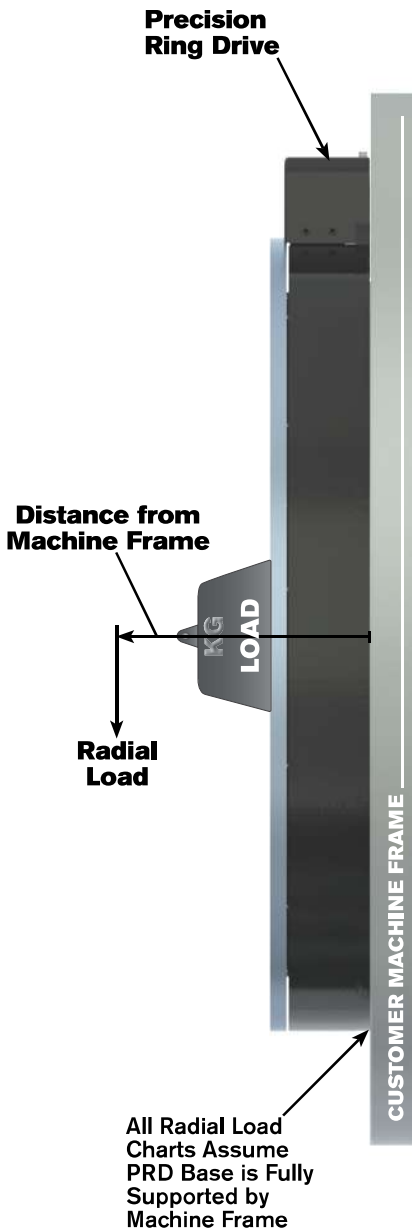

NOTE: The weight of the PRD is already factored into charts.

NOTE: There are no "Dynamic Load Limits by Drag Torque" for Radial Loads.

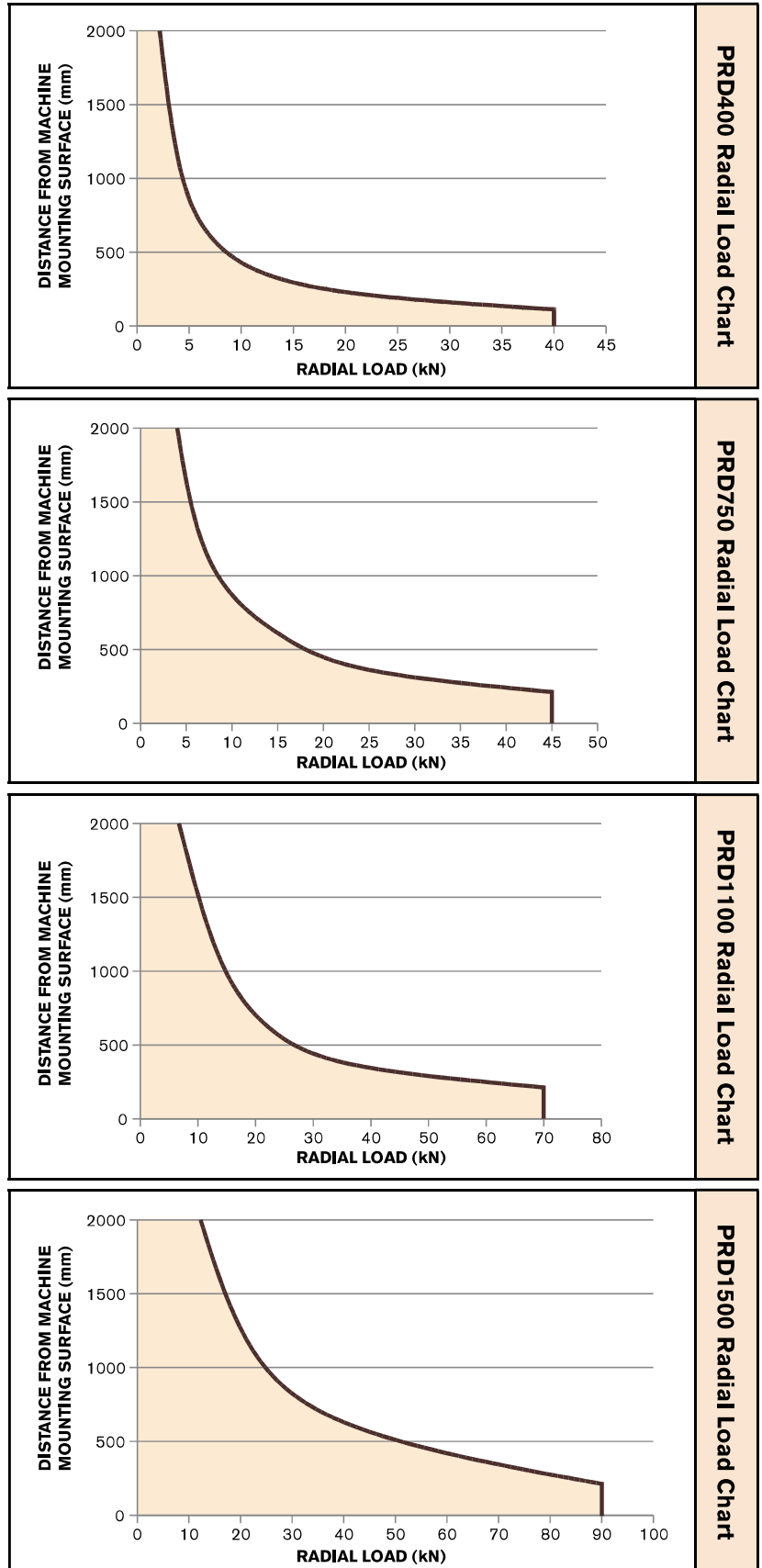

PRD Bearing Drag Torque Calculations

Bearing Drag Torque varies based on the load placed on the bearing. Use the calculations below to find the Bearing Drag Torque for your application.

STEP 1: GATHER APPLICATION DATA

Before you begin calculations, there are several key measurements that you will need from your application in order to calculate drag torque. Collect the data and record it in the space provided.

Measurements for Bearing Calculations	Customer Data (record your values below)	Sample Data
Unloaded Drag Torque of PRD (U_{Ldrag})	Nm	40 Nm
Maximum Dynamic Radial Load (F_{Rmax})	N	0 N
Maximum Dynamic Axial Load (F_{Amax})	N	54,300 N
Maximum Dynamic Moment Load (M_{max})	Nm	500 Nm

From PRD Specs

Note: The application's output torque (T_{maxApp}) applies a reaction force and moment to the bearing. Those forces create a negligible amount of drag and are therefore omitted from these calculations.

PRD Size	Bearing Rotation Diameters (dp)
PRD400	0.352 m
PRD750	0.700 m
PRD1100	1.050 m
PRD1500	1.440 m

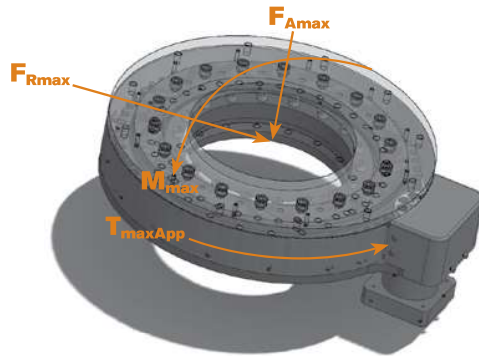

STEP 2: DETERMINE TOTAL DRAG TORQUE

$$T_{BD} = \left(\frac{15.3 * M_{max}}{dp} + (3.75 * F_{Amax}) + (8.19 * F_{Rmax}) \right) * dp * 10^{-3} + U_{Ldrag}$$

PRD TOTAL DRAG TORQUE

$$T_{BD} = \left(\frac{15.3 * \text{[]}}{\text{[]}} + (3.75 * \text{[]}) + (8.19 * \text{[]}) \right) * \text{[]} * 10^{-3} + \text{[]} \quad T_{BD} = \text{[]} \quad \text{Nm}$$

Sample: $T_{BD} = \left(\frac{15.3 * 500}{0.352} + (3.75 * 54,300) + (8.19 * 0) \right) * 0.352 * 10^{-3} + 40 = 119 \text{ Nm}$

STEP 3: COMPLETE OUTPUT TORQUE CALCULATIONS

Refer to the worksheet on Page 5 of Ring Drive Selection Process to calculate the Total Output Torque required for your application.

PRD Accessories: Dial Plates

Optional Dial Plates

Nexen offers customizable dial plates that precisely pilot on the output of Nexen Ring Drives. Contact Nexen to customize these plates for your application.

*Features shown shaded orange, are examples of customization.

	Standard Dial Plate Thickness	Standard Dial Plate Outer Diameter		
		550mm [21.65"]	900mm [35.43"]	1350mm [53.15"]
PRD400	19.05mm [0.75"]	967911	967912	967913
PRD750		N/A	967914	967915
PRD1100		N/A	N/A	967916
PRD1500		N/A	N/A	N/A

Contact Nexen to customize dial plate. Visit www.nexengroup.com

Common Customizations:

- ✓ Open Center
- ✓ Hole Patterns
- ✓ Pilots
- ✓ Cutouts
- ✓ Plate Diameter



PRD Accessories: Guarding Options

Guard Customization Options

When sizing a dial plate for Precision Ring Drives, it is important to note that the outer diameter of the dial plate will necessitate use of different guarding options. Listed below is the maximum dial plate diameter that can be used with the standard Full Guard. If a larger dial plate is desired, request a Partial Guard, or no Guard at all.

	Maximum Dial Plate Outer Diameter for Standard Guard
PRD400	550mm [21.65"]
PRD750	900mm [35.43"]
PRD1100	1350mm [53.15"]
PRD1500	1750mm [68.90"]

Contact Nexen to specify which guard is needed. Visit www.nexengroup.com



INDUSTRIES & APPLICATIONS

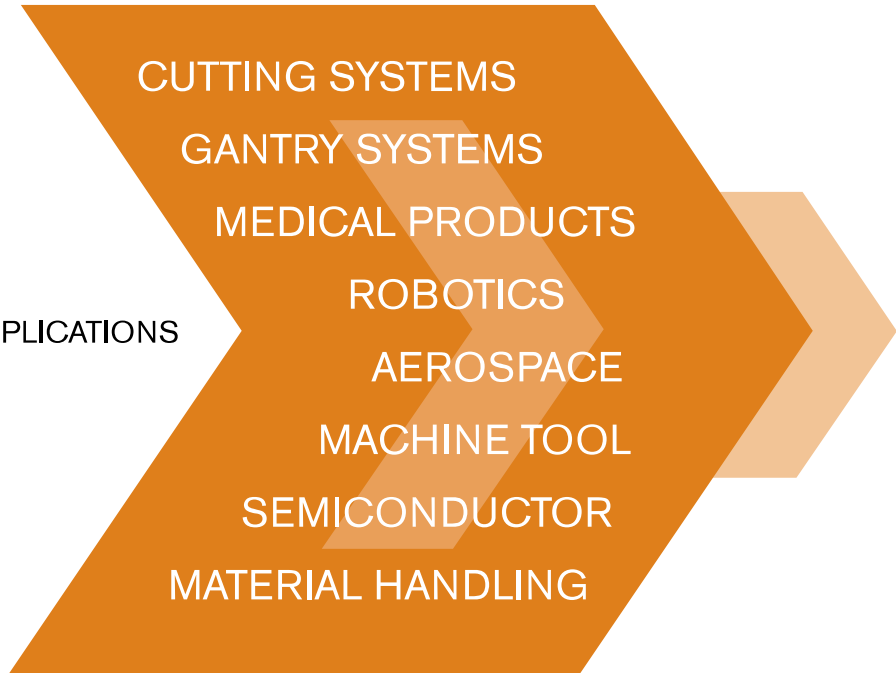

www.nexengroup.com

In accordance with Nexen's established policy of constant product improvement, the specifications contained in this document are subject to change without notice. Technical data listed in this document are based on the latest information available at the time of printing and are also subject to change without notice. For current information, please consult www.nexengroup.com or contact Nexen's Technical Support Group at the location to the right.

nexen[®]

Nexen Group, Inc.
560 Oak Grove Parkway
Vadnais Heights, MN 55127

(800) 843-7445
Fax: (651) 286-1099
www.nexengroup.com

Nexen has sales offices throughout the United States, Europe, Japan, and Australia.