

**Roulements d'orientation à deux rangées de billes, denture extérieure**

*Double row ball bearing, external toothed*

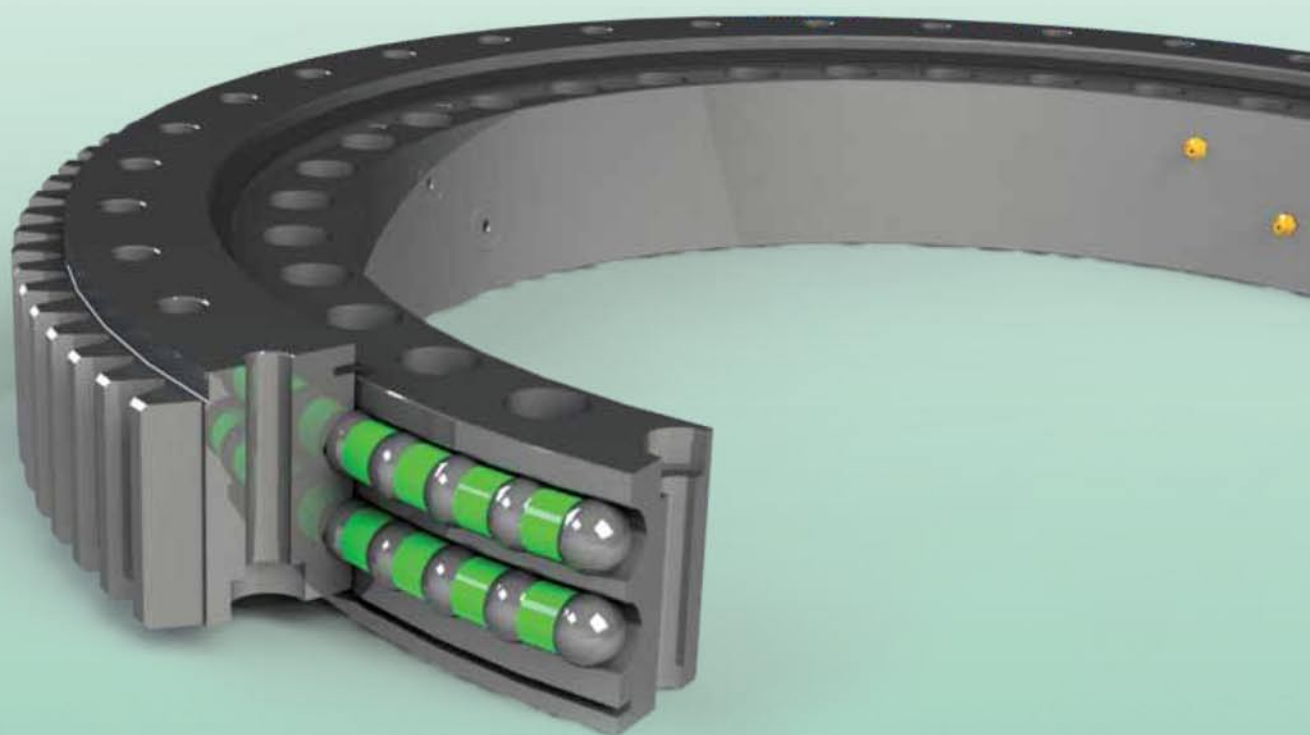

**EB2** SERIES

EB2

## SÉRIE STANDARD

STANDARD SERIES

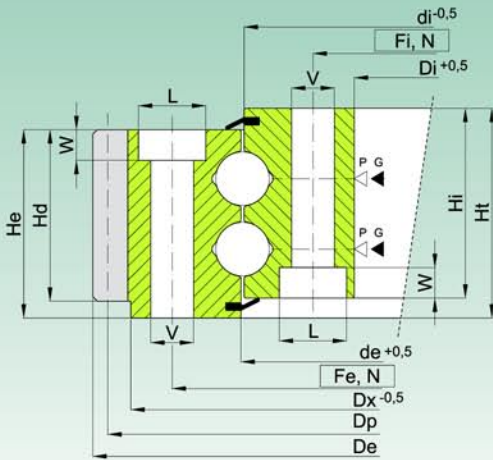

Code Code	Courbe Curve	Dimensions Dimensions								Trous de fixation Fixing Holes						Denture Gear data					Poids Weight [kg]		
		De [mm]	de [mm]	di [mm]	Di [mm]	Dx [mm]	He [mm]	Hi [mm]	Ht [mm]	Hd [mm]	Fe [mm]	Fi [-]	N [-]	V [mm]	L [mm]	W [mm]	m [mm]	Z [-]	xm [mm]	Dp [mm]		fz norm [kN]	fz max [kN]
EB2.22.0307.200-1SPPN	1	432	309	305	224	394	83	83	92	50	360	254	16	17	25	12	6	70	-	420	20,4	40,8	51
EB2.22.0383.200-1SPPN	2	504	385	381	300	466	83	83	92	75	436	330	16	17	25	12	8	61	-	488	40,8	81,6	64
EB2.25.0475.200-1SPPN	3	595	477	473	382	565	88	88	98	50	540	410	24	17	25	14	5	117	-	585	17	34	85
EB2.25.0575.200-1SPPN	4	712	577	573	470	670	88	88	98	75	640	508	24	17	25	9	8	87	-	696	40,8	81,6	123
EB2.20.0752.200-1SPPN	5	864	754	750	678	833	83	83	92	76	800	706	36	17	25	9	6	142	-	852	31,01	62,02	114
EB2.25.0821.200-1SPPN	6	979	823	819	718	935	92	92	102	86	893	753	36	21	31	15	10	94	+11	940	70,63	141,26	200
EB2.20.0968.200-1SPPN	7	1080	970	966	893	1042	83	83	92	76	1015	922	30	17	25	10	8	133	-	1064	41,34	82,69	148
EB2.25.1077.200-1SPPN	8	1200	1079	1075	976	1163	88	88	98	77	1135	1012	36	19	-	-	8	148	-	1184	41,89	83,78	210
EB2.28.1215.200-1SPPN	9	1380	1218	1212	1095	1330	98	98	108	90	1290	1135	48	23	34	16	10	136	-	1360	61,2	122,4	325

- Matériau: C45 Q+T

- Material C45 Q+T

- Possibilité de denture trempée (-1RPPN)

- Induction gear hardening available on request (-1RPPN)

▷ P=bouchon introduction billes / filling plug

▶ G= n.2+2 graisseurs M8X1 / n.2+2 greasers M8X1

DIAGRAMME DE CHARGE STATIQUE POUR CONTRAINTES DE COMPRESSION  
 STATIC LOAD CHARTS VALID FOR COMPRESSIVE LOADS

## COURBES / CURVES 1~6

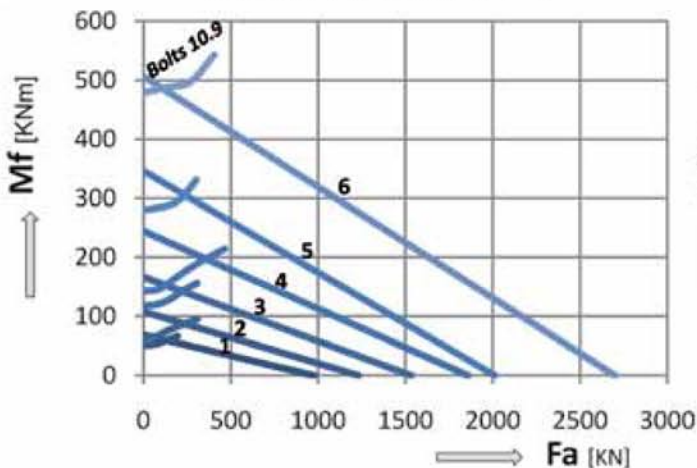

## COURBES / CURVES 7~9

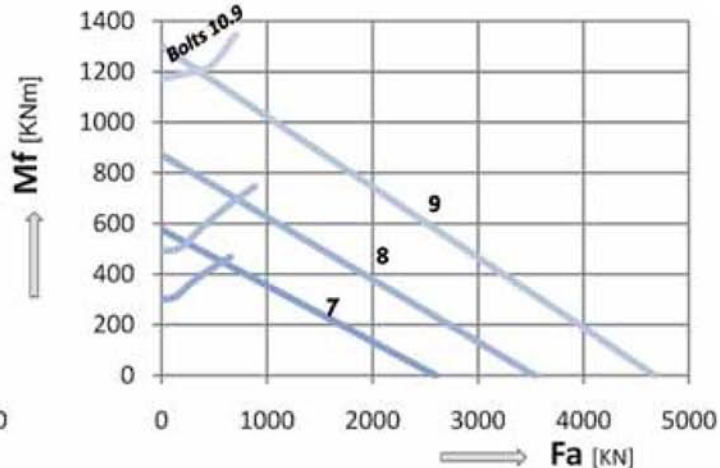

Lire les instructions techniques - partie 2 - pour l'utilisation correcte du graphique - Please read technical instruction - part 2 - for correct use of load graph.

EB2

SÉRIE STANDARD

STANDARD SERIES

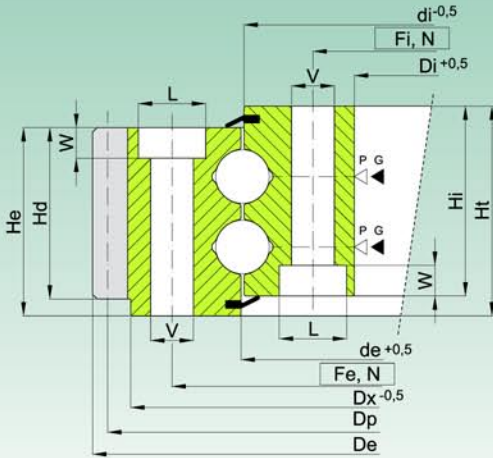

Code Code	Courbe Curve	Dimensions Dimensions								Trous de fixation Fixing Holes						Denture Gear data					Poids Weight		
		De	de	di	Di	Dx	He	Hi	Ht	Hd	Fe	Fi	N	V	L	W	m	Z	xm	Dp		fz norm	fz max
		[mm]	[mm]	[mm]	[mm]	[mm]	[mm]	[mm]	[mm]	[mm]	[mm]	[-]		[mm]	[-]	[mm]	[-]	[mm]	[mm]	[mm]		[kN]	[kN]
EB2.22.0383.400-1SPPN	1	504	385	381	300	394	83	83	92	75	436	330	16	17	25	12	8	61	-	488	48	96	64
EB2.25.0475.400-1SPPN	2	614,4	477	473	378	565	88	88	98	80	540	410	24	19	28	14	8	74	+4	592	51,2	102,4	98
EB2.25.0575.400-1SPPN	3	695	577	573	470	670	83	83	92	58	640	508	30	17	25	13	5	136	+2,5	680	23,2	46,4	104
EB2.25.0980.400-1RPPN	4	1144	982	978	870	1096	96	96	110	88	1050	910	36	21	31	12	10	111	+8	1110	85,02	170,05	262
EB2.28.1117.400-1SPPN	5	1289	1120	1114	985	1240	98	98	108	83	1198	1035	40	21	31	18	10	125	+10,5	1250	80,19	160,39	332
EB2.28.1215.400-1SPPN	6	1380	1218	1212	1095	1330	98	98	108	90	1290	1135	36	23	34	16	10	136	-	1360	72	144	334
EB2.30.1249.400-1SPPN	7	1476	1252	1246	1085	1415	101	101	110	89	1350	1150	48	26	37	23	10	144	+8,6	1440	85,99	171,98	502

- Matériau: 42CrMo4 Q+T

- Material: 42CrMo4 Q+T

- Pleins de graisse, protégés par huile et enveloppés dans un film plastique résistant - Full of grease, protected by oil and wrapped in resistant plastic film

- Possibilité de denture trempée (-1RPPN)

- Induction gear hardening available on request (-1RPPN)

▷ P=bouchon introduction billes / filling plug

▶ G= n.2+2 graisseurs M8X1 / n.2+2 greasers M8X1

DIAGRAMME DE CHARGE STATIQUE POUR CONTRAINTES DE COMPRESSION  
STATIC LOAD CHARTS VALID FOR COMPRESSIVE LOADS

COURBES / CURVES 1~3

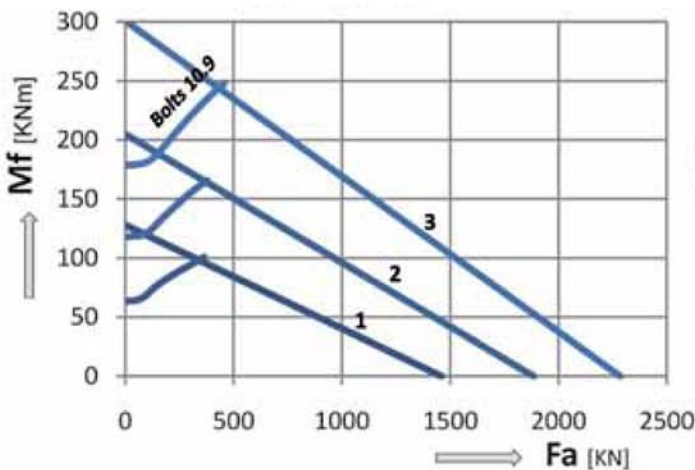

COURBES / CURVES 4~7

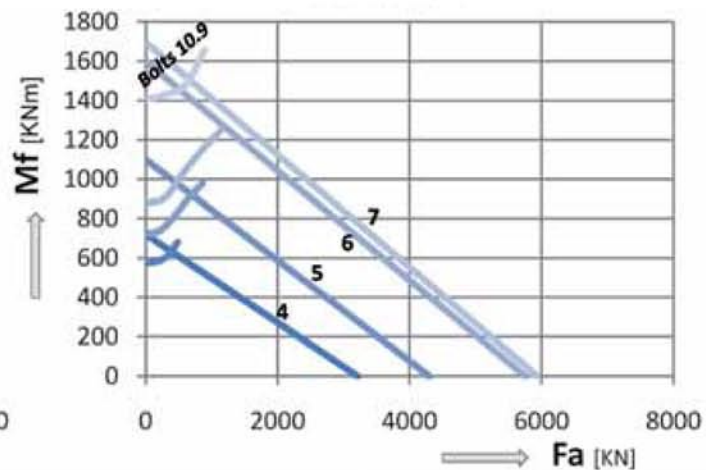

Lire les instructions techniques - partie 2 - pour l'utilisation correcte du graphique - Please read technical instruction - part 2 - for correct use of load graph.

EB2

## SÉRIE STANDARD

STANDARD SERIES

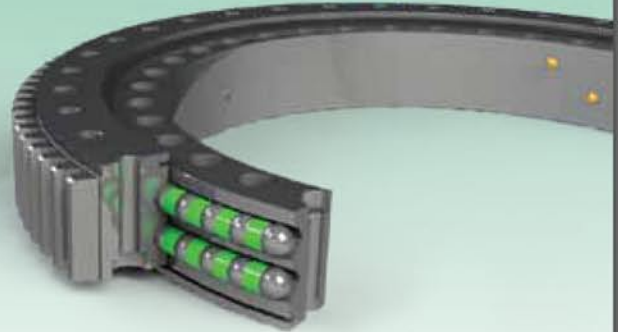
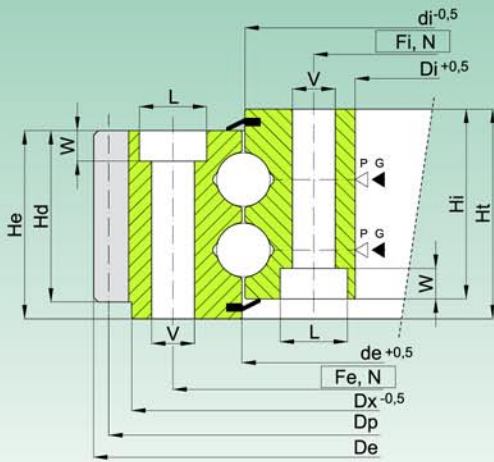

Code Code	Courbe Curve	Dimensions Dimensions								Trous de fixation Fixing Holes						Denture Gear data				Poids Weight [kg]			
		De [mm]	de [mm]	di [mm]	Di [mm]	Dx [mm]	He [mm]	Hi [mm]	Ht [mm]	Hd [mm]	Fe [mm]	Fi [-]	N [mm]	V [mm]	L [mm]	W [mm]	m [mm]	Z [-]	xm [mm]		Dp [mm]	fz norm [kN]	fz max [kN]
EB2.35.1249.400-1SPPN	1	1472	1252	1246	1085	1406	134	134	144	115	1350	1150	36	28	41	27	14	102	+9,1	1428	147,78	295,56	640
EB2.30.1391.400-1SPPN	2	1603	1394	1388	1208	-	110	110	120	110	1500	1280	40	29	-	-	10	157	+7,5	1570	100,97	201,93	636
EB2.35.1402.401-1SPPN	3	1604	1405	1399	1208	1570	134	134	144	93	1500	1280	48	31	46	28	10	157	+7	1570	147,78	295,56	710
EB2.25.1391.400-1SPPN	4	1605	1394	1388	1208	1550	116	116	130	96	1494	1280	48	29	41	22	12	130	+12	1560	105,74	211,48	623
EB2.35.1390.400-1SPPN	5	1634	1393	1387	1208	-	138	134	148	138	1500	1280	48	31	46	24	14	113	+14	1582	177,33	354,67	800
EB2.30.1578.400-1SPPN	6	1808	1581	1575	1404	-	110	110	120	110	1680	1476	40	29	-	-	10	178	+5	1780	100,97	201,93	754
EB2.35.1578.400-1SPPN	7	1805	1581	1575	1433	-	140	140	156	140	1671	1485	60	28	41	15	16	109	+16,9	1744	205,6	411,21	810

- Matériau: 42CrMo4 Q+T

- Material: 42CrMo4 Q+T

- Pleins de graisse, protégés par huile et enveloppés dans un film plastique résistant - Full of grease, protected by oil and wrapped in resistant plastic film

- Possibilité de denture trempée (-1RPPN)

- Induction gear hardening available on request (-1RPPN)

▷ P=bouchon introduction billes / filling plug

▷ G = n.2+2 graisseurs M8X1 / n.2+2 greasers M8X1

DIAGRAMME DE CHARGE STATIQUE POUR CONTRAINTES DE COMPRESSION  
 STATIC LOAD CHARTS VALID FOR COMPRESSIVE LOADS

## COURBES / CURVES 1,3,6,7

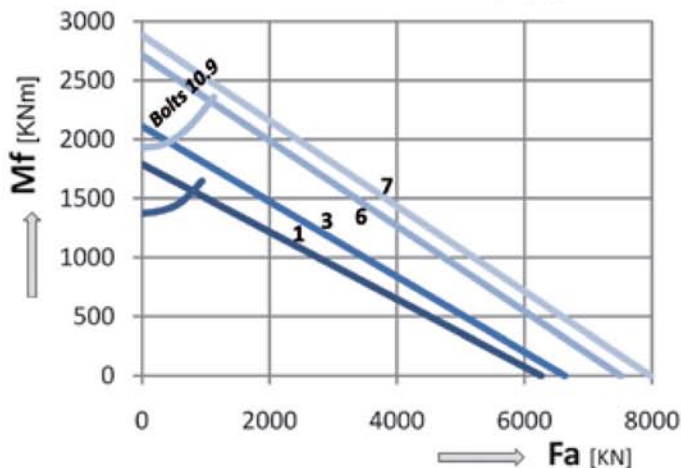

## COURBES / CURVES 2,4,5

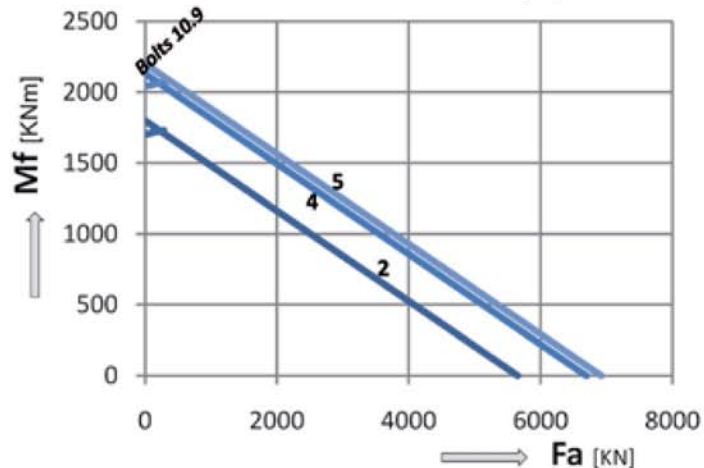

Lire les instructions techniques - partie 2 - pour l'utilisation correcte du graphique - Please read technical instruction - part 2 - for correct use of load graph.