

MRD Disc Brake Caliper - Pneumatically Applied, Spring Released

Nominal dimensions are given
For caliper dimensions see DS2000

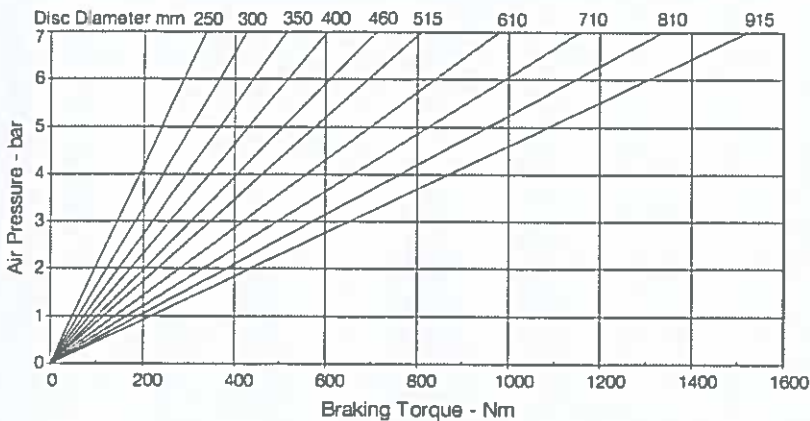
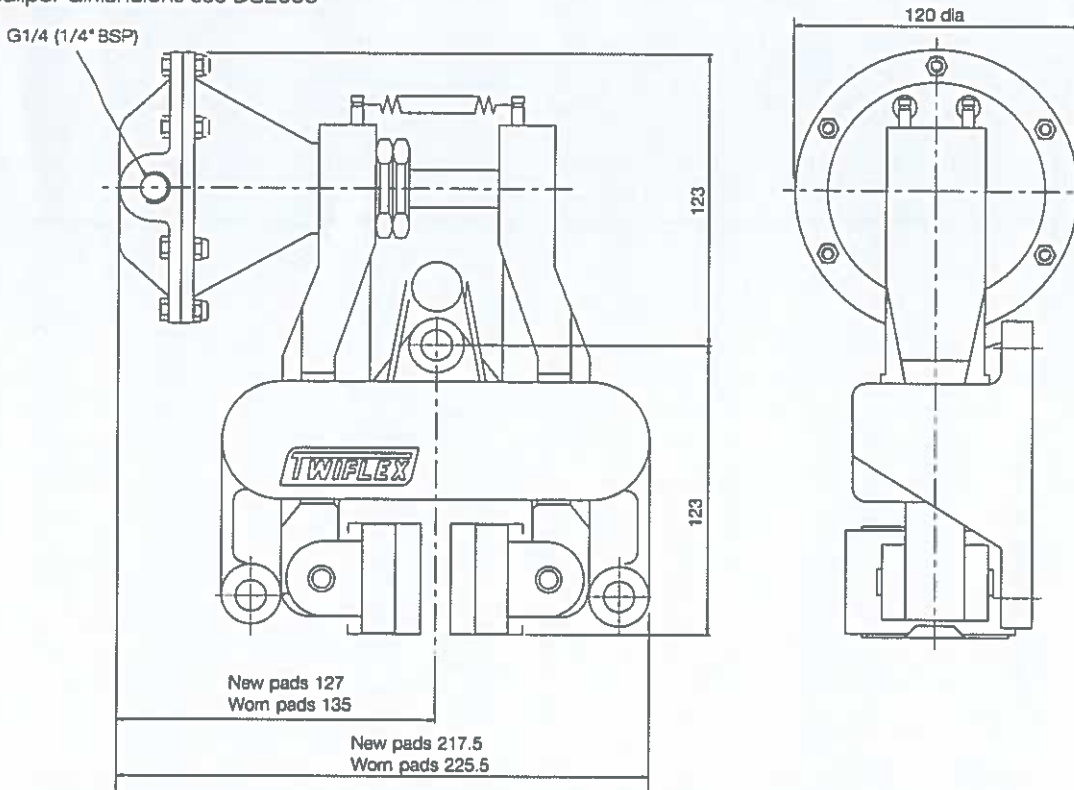

Weight (caliper and thruster) - 7.65kg
(thruster only) - 1.15kg
Volume displacement of thruster at full stroke is 150ml.

Maximum pressure 7 bar
Maximum Braking Force - 3.6kN @7bar

The ratings shown on the above graph are based on fully bedded and conditioned brake pads with nominal friction coefficient $\mu=0.4$.

For bedding-in and conditioning procedures see Publication M1060.

Braking Force is defined as the Tangential Force acting on the brake disc at the Effective Disc Radius.
Braking Torque (Nm) = Braking Force (N) x Effective Disc Radius (m) where Effective Disc Radius = Actual Disc Radius - 0.03.

Twiflex Disc Brakes must be used with Twiflex asbestos free brake pads. The use of any other brake pads will invalidate the warranty. Twiflex Limited reserves the right to modify or change the design without prior notice.

MRD Disc Brake Caliper - Pneumatically Applied, Spring Released

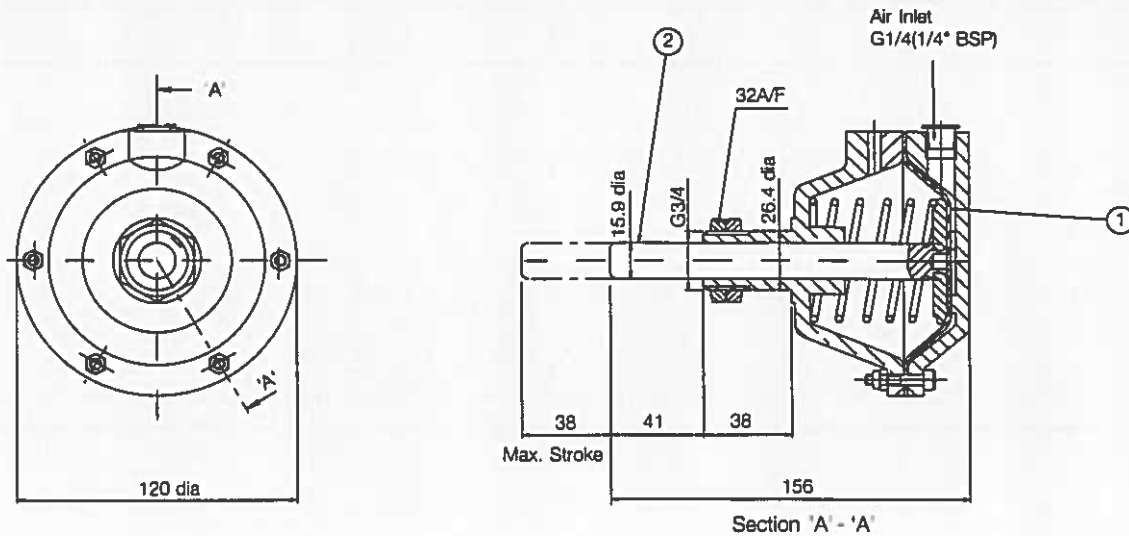

This range of pneumatically operated brakes uses dry and filtered compressed air at pressures up to 7 bar. Pneumatic brakes require a control valve which may be operated either manually, or by pneumatic or electrical signal.

Should it become necessary to replace a diaphragm, ensure air supply is disconnected, remove the M5 bolts and the rear cap of the thruster. Remove the worn diaphragm; clean-up the contacting surfaces and re-assemble with the new diaphragm and bolts in position. (Tightening Torque 5.7Nm)

Thruster Fitment

1. Offer thruster to caliper making sure that both lock nuts are removed before placing push rod through caliper arm.
2. Fit lock nuts over the push rod and locate its end within the slot of the other arm.
3. Tighten one lock nut to 50-60 Nm then tighten the second nut against the first.

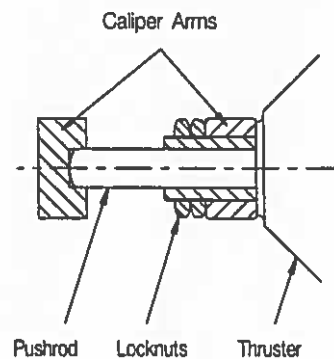

Thruster Part Number 7200863

Available Spares		
Item	Component	Part No.
1	Diaphragm Kit	7902799
2	Piston Rod Assembly	7200802