

## MRK Disc Brake Caliper - Spring Applied, Pneumatically Released

Nominal dimensions given  
For caliper dimensions see DS2000

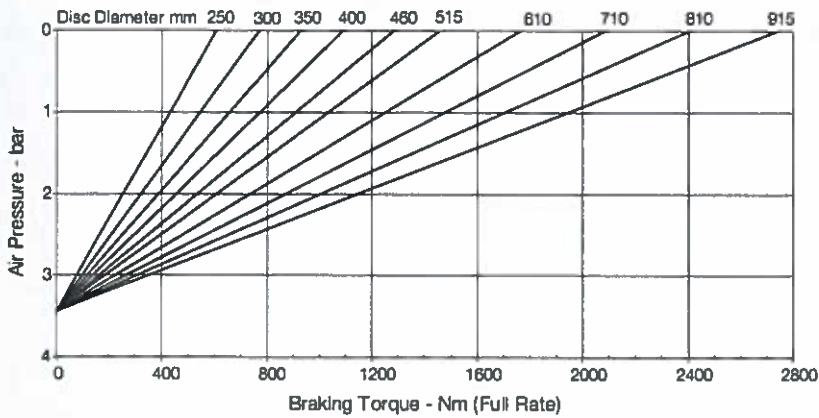
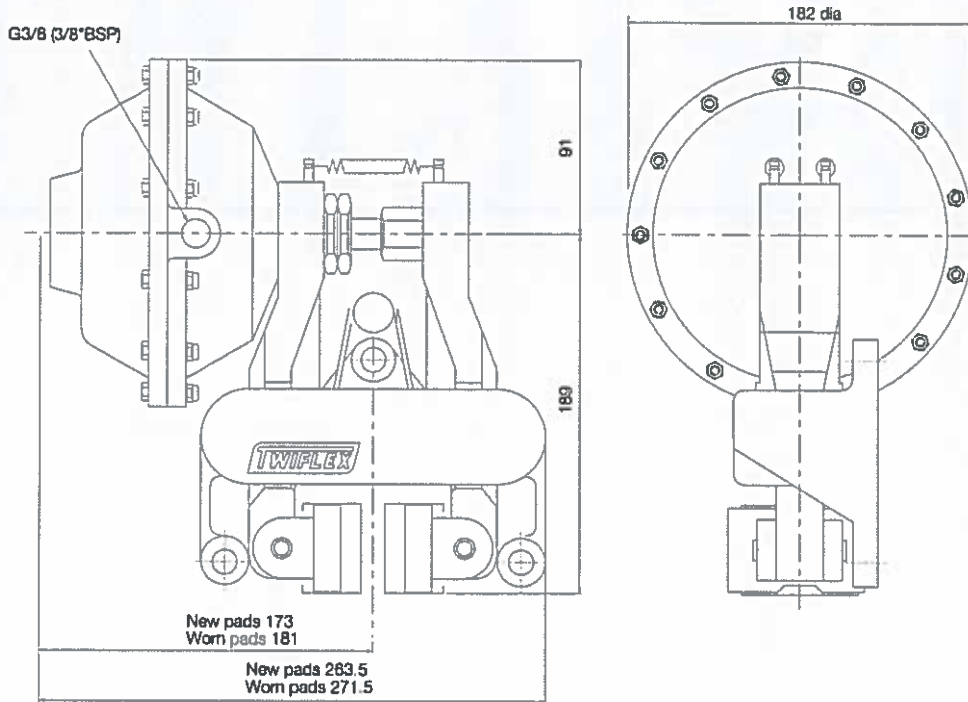

Weight (caliper and thruster) - 10.0kg  
(thruster only) - 3.5kg  
Total volume of air at full retraction is 0.95l

**Maximum working pressure 7 bar**

Rate	Maximum Braking Force - kN	Minimum Pressure for Full Retraction - bar
Full	6.4	5
2/3	4.3	3.3
1/3	2.2	1.7

The ratings shown on the above graph are based on fully bedded and conditioned brake pads with nominal friction coefficient  $\mu = 0.4$ .  
For bedding-in and conditioning procedures see Publication M1060.

Braking Force is defined as the Tangential Force acting on the brake disc at the Effective Disc Radius.  
Braking Torque (Nm) = Braking Force (N) x Effective Disc Radius (m) where Effective Disc Radius = Actual Disc Radius - 0.03.

Twiflex Disc Brakes must be used with Twiflex asbestos free brake pads. The use of any other brake pads will invalidate the warranty.

Twiflex Limited reserves the right to modify or change the design without prior notice.

# MRK Disc Brake Caliper - Spring Applied, Pneumatically Released

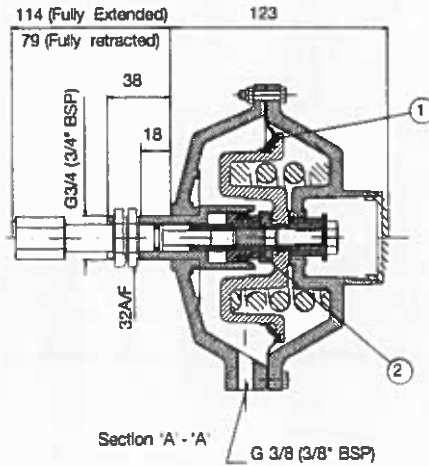
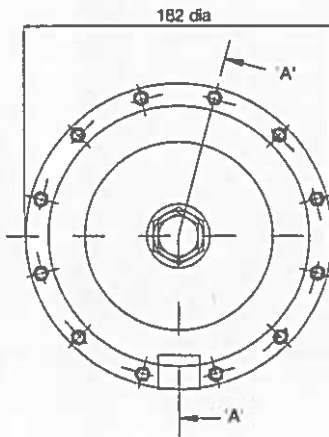

## AVAILABLE SPARES

Item	Component	Part No.
1	Diaphragm Kit	7902804
2	Self Adjusting Repair Kit	7902805
	Spring Kit	7902800

## Thruster Part Numbers

Full Rate 7200654

2/3rd Rate 7200770

1/3rd Rate 7200576

This range of pneumatically operated brakes uses dry and filtered compressed air at pressures up to 7 bar. Pneumatic brakes require a control valve which may be operated either manually, or by pneumatic or electrical signal.

Should it become necessary to replace a diaphragm, Remove from caliper and ensure air supply is disconnected. Unscrew and remove push rod. Remove the M5 bolts and the rear cap of the thruster. Remove the worn diaphragm; clean-up the contacting surfaces and re-assemble with the new diaphragm and M5 bolts in position (Tightening Torque 5.7Nm).

## Thruster Fitment

1. Make sure the thruster rod is extended i.e. it is not pressurised.
2. Take hold of the thruster and turn the push rod via the hex portion clockwise until it stops rotating: so a 'clicking' can be heard from the ratchet . Do this by hand, do not apply heavy force to push the rod once it stops turning.
3. Offer thruster to caliper making sure that both lock nuts are removed before placing hex section of push rod through caliper arm.
4. Pull caliper arms apart so that the pads are hard against the disc.
5. Fit lock nuts to thruster body loosely and unwind push rod until the gap between the body and the arm is 6mm. Make sure that the hex section of the push rod is within the slot of the other arm.
6. Tighten first lock nut to 50 - 60Nm then tighten the second nut against the first.
7. Fit tension spring to arms.

