

## MSK Disc Brake Caliper - Spring Applied, Pneumatically Released

Nominal dimensions given  
For caliper dimensions see DS1500

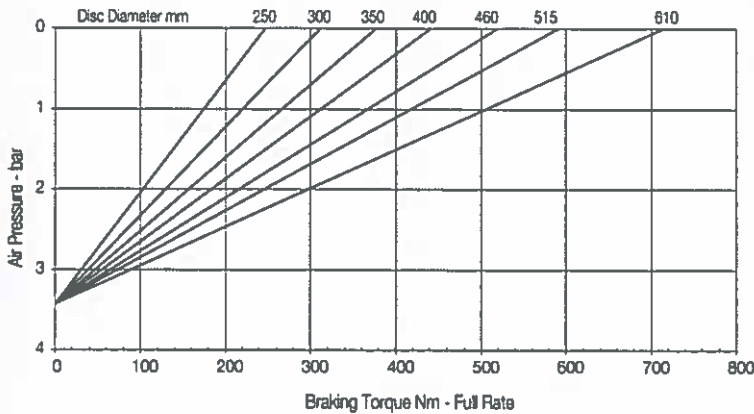
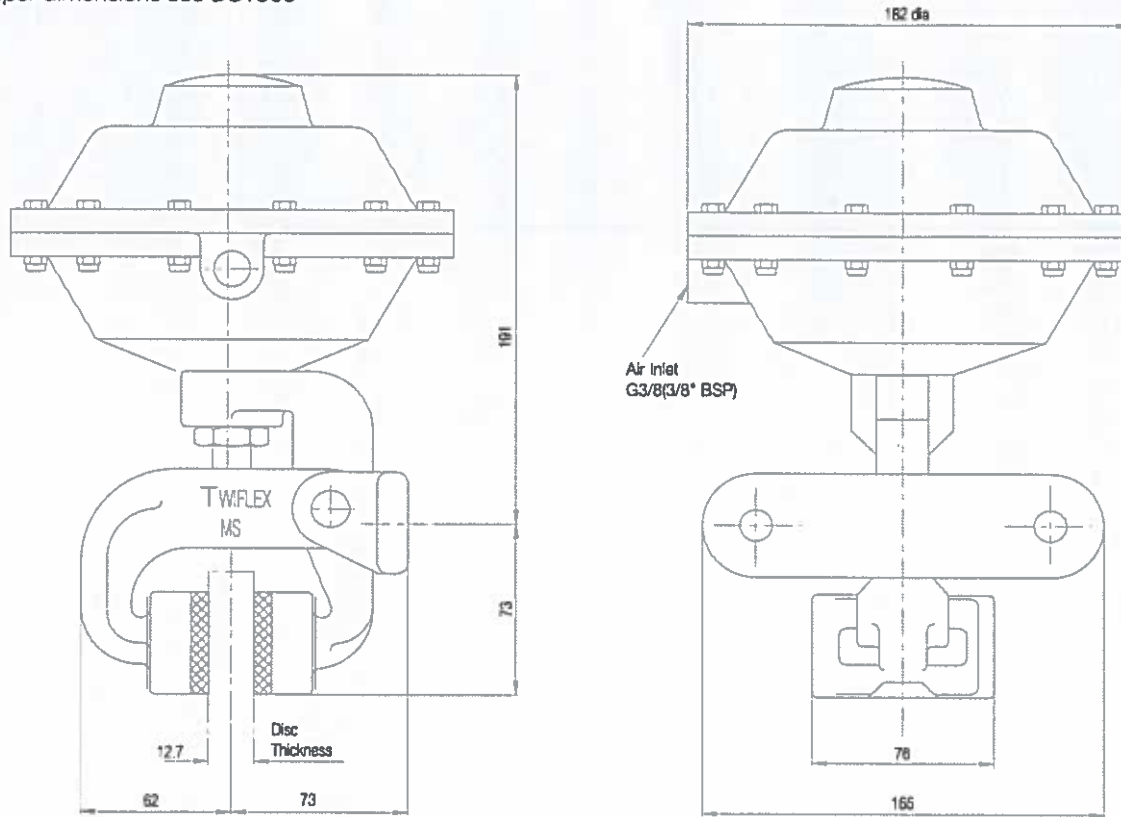

Weight (caliper and thruster) - 4.9kg  
Weight (thruster only) - 3.4kg  
Volume displacement of thruster at full retraction = 0.95 l.

### Maximum working pressure 7 bar

Rate	Maximum Braking Force - kN	Minimum Pressure for Full Retraction - bar
Full	2.6	5
2/3	1.74	3.3
1/3	0.87	1.7

The ratings shown on the above graph are based on fully bedded and conditioned brake pads with nominal friction coefficient  $\mu = 0.4$ .

For bedding-in and conditioning procedures see Publication M1060.

Braking Force is defined as the Tangential Force acting on the brake disc at the Effective Disc Radius.

Braking Torque (Nm) = Braking Force (N) x Effective Disc Radius (m) where Effective Disc Radius = Actual Disc Radius - 0.03.

Twiflex Disc Brakes must be used with Twiflex asbestos free brake pads. The use of any other brake pads will invalidate the warranty.

Twiflex Limited reserves the right to modify or change the design without prior notice.

# MSK Disc Brake Caliper - Spring Applied, Pneumatically Released

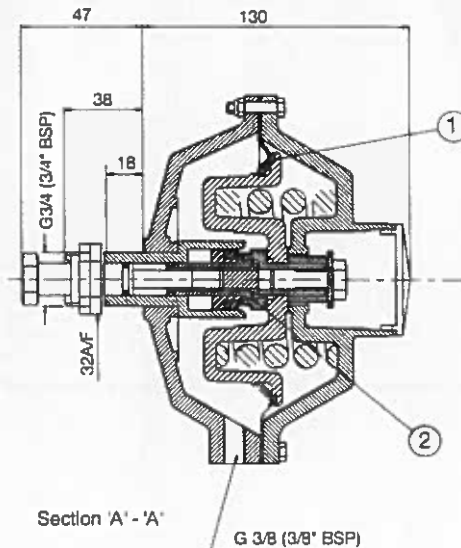
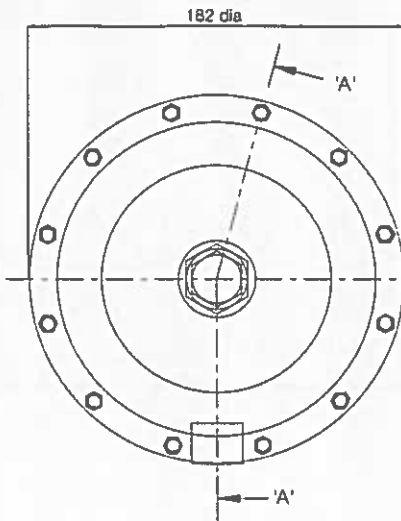

## AVAILABLE SPARES

Item	Component	Part No.
1	Diaphragm Kit	7902804
2	Self Adjusting Repair Kit	7902805
3	Spring Kit (for full rate)	7902800

## Thruster Part Numbers

MSK Full rate 7200626

MSK 2/3rd rate 7200862

MSK 1/3rd rate 7200698

This range of pneumatically operated brakes uses dry and filtered compressed air at pressures up to 7 bar. Pneumatic brakes require a control valve which may be operated either manually, or by pneumatic or electrical signal.

Should it become necessary to replace a diaphragm, Remove from caliper and ensure air supply is disconnected. Unscrew and remove push rod. Remove the M5 bolts and the rear cap of the thruster. Remove the worn diaphragm; clean-up the contacting surfaces and re-assemble with the new diaphragm and M5 bolts in position (Tightening Torque 5.7Nm).

## Thruster Fitment with Thruster Unpressurised

1. Take hold of the thruster and turn push rod clockwise' using the hexagonal portion, until it stops retracting: at this point a clicking noise from the ratchet will be heard. Do this by hand, do not use excessive force.
2. Remove the lock nuts and offer the thruster to the caliper, passing the hexagonal end of the push rod through the arm. Loosely re-fit the lock nuts.
3. Unscrew the push rod until the gap between the arm and the thruster body is 6 mm, when the hexagon is located in the slot in the opposite arm, and the pads are in firm contact with the disc.
4. Tighten the inner lock nut to 50-60 Nm; this will compress the thruster spring and reduce the gap to zero. Then tighten the second lock nut against the first.

