

MXB Disc Brake Caliper - Pneumatically Applied, Spring Released

Nominal Dimensions given
For caliper dimensions see DS2500

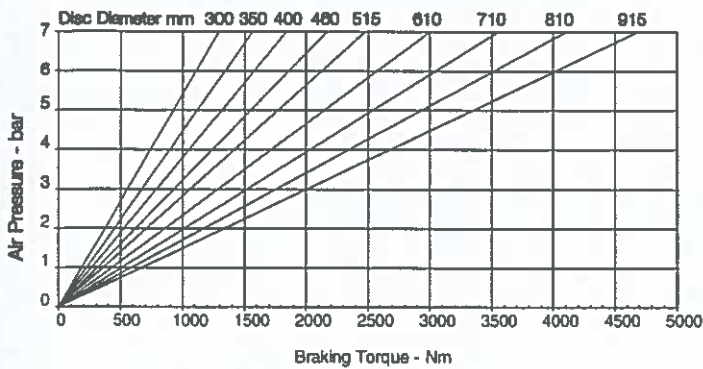
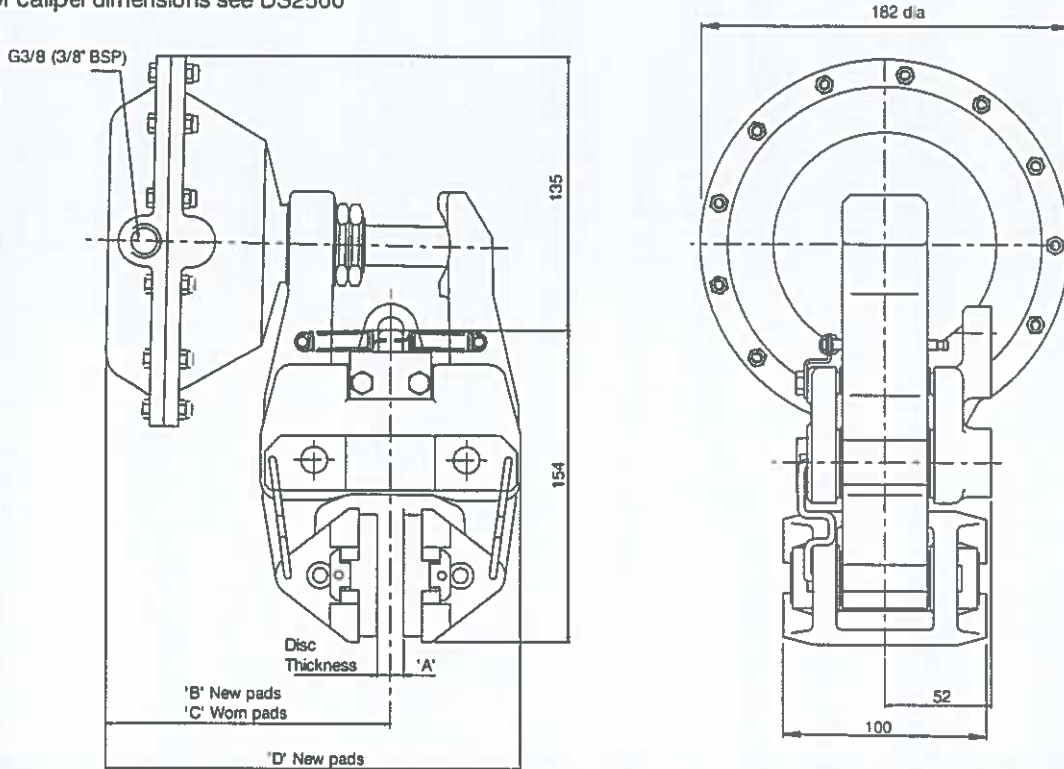

Caliper	Dimensions in mm			
	'A'	'B'	'C'	'D'
MXB 13	12.7	142	150	207
MXB 25	25.4	148	156	215
MXB 30	30	142	150	213
MXB 40	40	148	156	223

Weight (caliper and thruster) - 9.06kg
(thruster only) - 2.06kg

Volume displacement of thruster at full stroke is 426ml.

Maximum pressure 7 bar

Maximum Braking Force - 11kN @ 7 bar

The ratings shown on the above graph are based on fully bedded and conditioned brake pads with nominal friction coefficient $\mu=0.4$.

For bedding-in and conditioning procedures see Publication M1060.

Braking Force is defined as the Tangential Force acting on the brake disc at the Effective Disc Radius.

Braking Torque (Nm) = Braking Force (N) x Effective Disc Radius (m) where Effective Disc Radius = Actual Disc Radius - 0.033.

Twiflex Disc Brakes must be used with Twiflex asbestos free brake pads. The use of any other brake pads will invalidate the warranty. Twiflex Limited reserves the right to modify or change the design without prior notice.

MXB Disc Brake Caliper - Pneumatically Applied, Spring Released

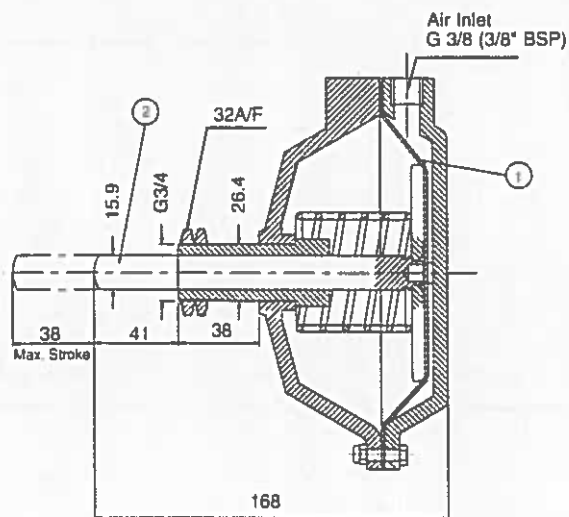
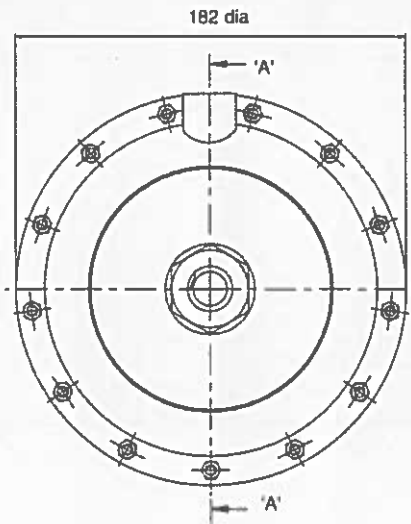

Section 'A' - 'A'

This range of pneumatically operated brakes uses dry and filtered compressed air at pressures up to 7 bar. Pneumatic brakes require a control valve which may be operated either manually, or by pneumatic or electrical signal.

Should it become necessary to replace a diaphragm, ensure air supply is disconnected, remove the M5 bolts and the rear cap of the thruster. Remove the worn diaphragm; clean-up the contacting surfaces and re-assemble with the new diaphragm and bolts in position. (Tightening Torque 5.7Nm)

Thruster Part Number 7200829

Available Spares		
Item	Component	Part No.
1	Diaphragm Kit	7902803
2	Piston Rod Assembly	7200803

Thruster Fitment

1. Offer thruster to caliper making sure that both lock nuts are removed before placing push rod through caliper arm.
2. Fit lock nuts over the push rod and locate it's end within the slot of the other arm.
3. Tighten one lock nut to 50-60 Nm then tighten the second nut against the first.

