

MXG Disc Brake Caliper - Pneumatically Applied, Spring Released

Nominal Dimensions given
For caliper dimensions see DS2500

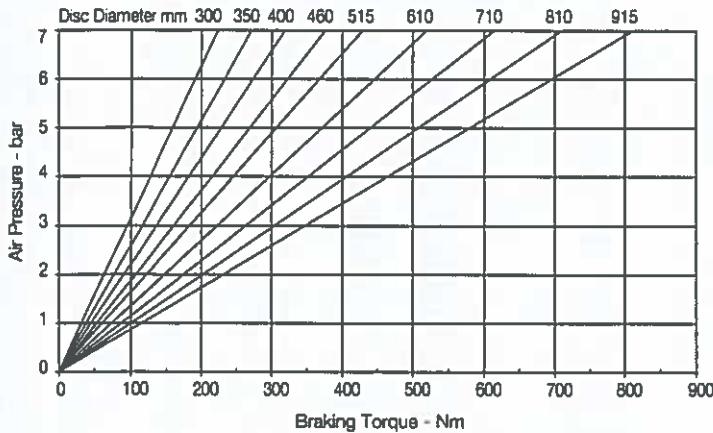
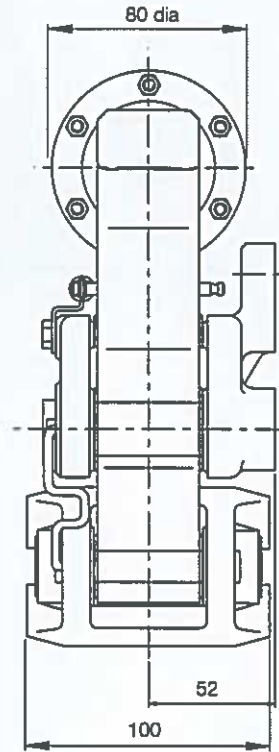
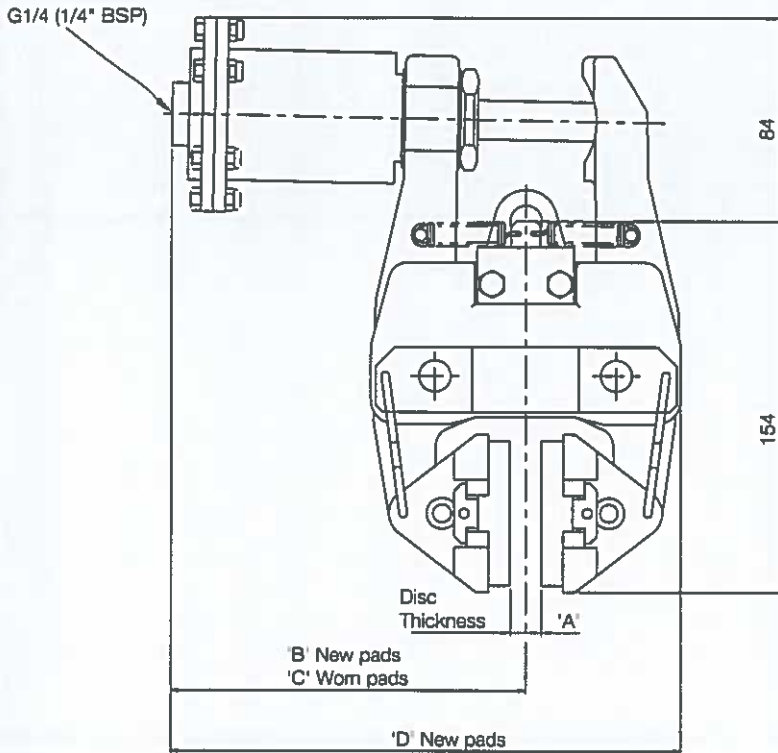

Caliper	Dimensions in mm			
	'A'	'B'	'C'	'D'
MXG 13	13	148.5	156.5	213.5
MXG 25	25	153	161	220
MXG 30	30	148.5	156.5	219.5
MXG 40	40	153	161	228

Weight (caliper and thruster) - 7.3kg
(thruster only) - 0.3kg

Volume displacement of thruster at full stroke is 64ml.

Maximum pressure 7 bar

Maximum Braking Force - 1.9kN @ 7 bar

The ratings shown on the above graph are based on fully bedded and conditioned brake pads with nominal friction coefficient $\mu=0.4$.

For bedding-in and conditioning procedures see Publication M1060.

Braking Force is defined as the Tangential Force acting on the brake disc at the Effective Disc Radius.

Braking Torque (Nm) = Braking Force (N) x Effective Disc Radius (m) where Effective Disc Radius = Actual Disc Radius - 0.033.

Twiflex Disc Brakes must be used with Twiflex asbestos free brake pads. The use of any other brake pads will invalidate the warranty. Twiflex Limited reserves the right to modify or change the design without prior notice.

MXG Disc Brake Caliper - Pneumatically Applied, Spring Released

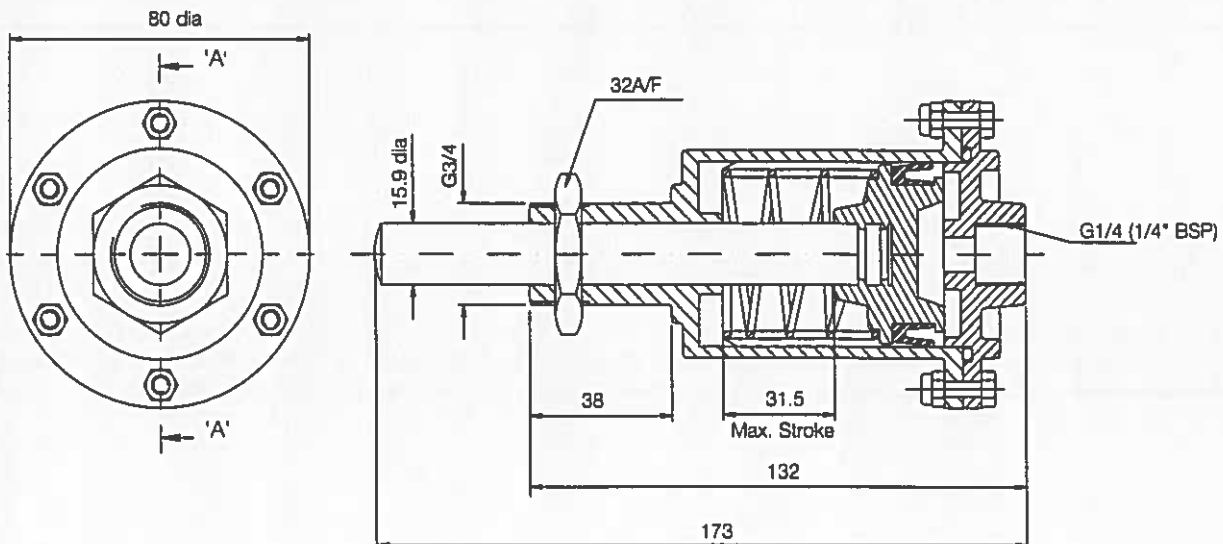

Section 'A' - 'A'

Thruster Part Number 7200434

This range of pneumatically operated brakes uses dry and filtered compressed air at pressures up to 7 bar. Pneumatic brakes require a control valve which may be operated either manually, or by pneumatic or electrical signal.

Thruster Fitment

1. Offer thruster to caliper making sure that the lock nuts is removed before placing push rod through caliper arm.
2. Fit the lock nut over the push rod and locate it's end within the slot of the other arm.
3. Tighten the lock nut to 50-60 Nm.

